

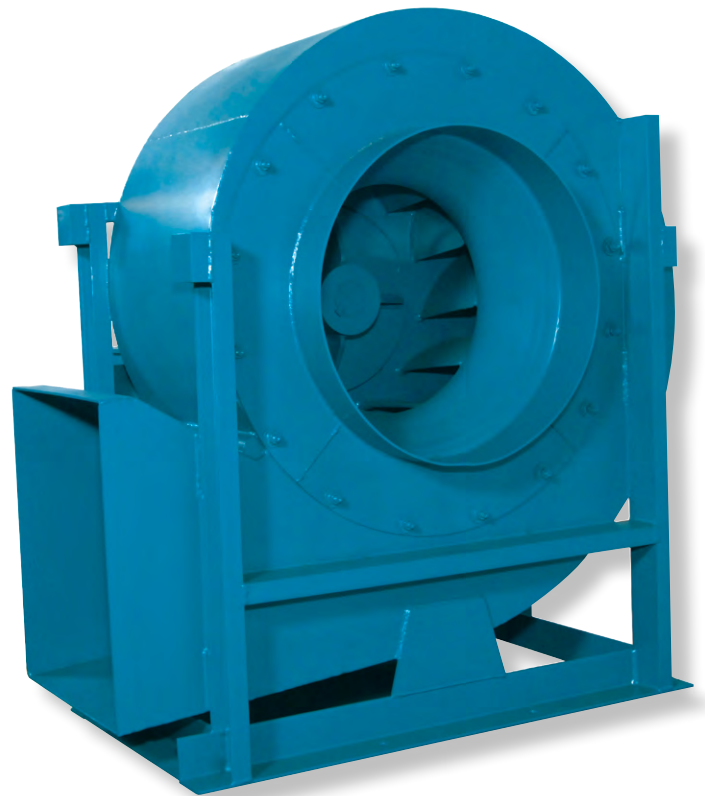

INDUSTRIAL PROCESS AND
COMMERCIAL VENTILATION SYSTEMS

RADIAL TIP FANS

MODEL RTF



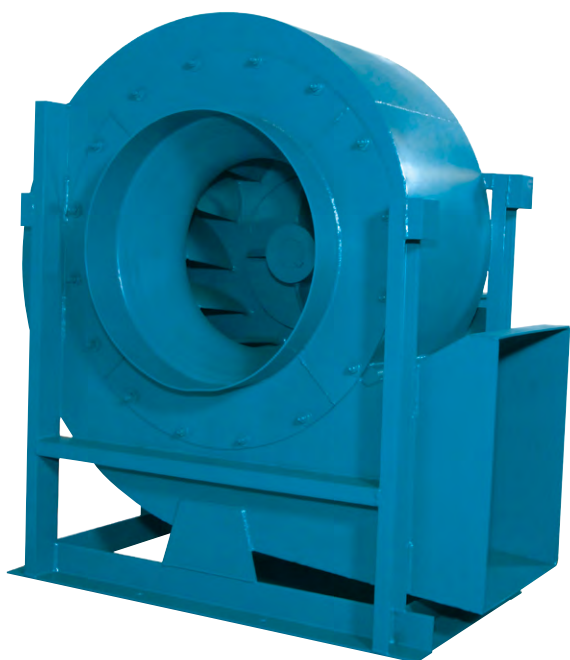

Model RTF
Arr. 1

Model RTF

Model RTF radial tip fans are of a heavy duty, rugged design, suitable for applications involving large volumes of gas streams at moderate to high pressure. Designed to handle clean or dirty airstreams, they are widely used to exhaust gases from bag-type collectors, precipitators, scrubbers, cyclones, and other industrial applications. This type of fan is also used for induced draft on boilers, incinerators, and kiln exhaust. Steel, air pollution, dryer, petrochemical, cement, furnaces and ovens, solvent recovery, sewage sludge and solid waste incineration industries have found the Model RTF radial tip design particularly suitable for their applications.

Capabilities

- Heavy-duty construction with choice of speed range:
 - Class 18** — Suitable to 91 m/s tip speed
Pressures to 5960 Pa
 - Class 23** — Suitable to 117 m/s tip speed
Pressures to 8950 Pa
- Class 23 Impellers are equipped with wear pads on the blades. Consult factory for higher tip speed designs.
- Volume flow to 106 m³/sec.
- Standard fan suitable to 148°C.

Features

- High efficiency, for lower operating costs.
- AMCA licensed air performance on sizes 270 through 800, pages 11 to 22.
- Self-cleaning impeller design.
- Statically and dynamically balanced rotor assembly.
- Heavy duty, self-aligning, grease lubricated, anti-friction, pillow block bearings.
- Heavy-gauge reinforced housing and bearings pedestal for vibration-free service.



Twin City Fan & Blower certifies that the RTF Radial Tip Fans Sizes 270 through 800 shown on pages 11 to 22 are licensed to bear the AMCA Seal. The ratings shown are based on tests and procedures performed in accordance with AMCA Publication 211 and comply with the requirements of the AMCA Certified Ratings Program.



Inlet Boxes

Integral or detached type, generously designed to minimise pressure drop. Specify inlet box position to AMCA Standard 2405-66 shown on page 4. Detached inlet boxes include support legs and flanges on both inlet and outlet. Free-standing designs are also available to allow a flexible connector between box and fan. Standard detached inlet box will not support stack weight. All inlet box designs include drain and access door.

Inlet Box Dampers

Pre-spin design, heavy duty construction. The damper will spin the air in the direction of impeller rotation resulting in a savings in horsepower at reduced loads.

Outlet Dampers

Double surface airfoil blades are available in either parallel or opposed blade design.

Abrasion and Corrosion Resistant Alloys and Coatings

Optional construction includes an abrasion resistant steel blade, backplate, scroll and side or cheek liners. Construction materials include Corten, stainless steel, Monel, aluminium, Hastelloy, and other alloys. Construction from heavier than standard gauges is available. Special corrosion resistant coatings of various types are available.

Temperature and Vibration Detectors

Thermocouples or RTDs can be installed on the bearings. Various types of vibration switches are available.

Evasé

Usually fabricated by customer as a part of the ductwork. Fan outlet must be expanded to equal evasé area shown in the catalogue to obtain rated performance. Construction is of the same gauge as fan housing when purchased from the factory.

High Temperature Construction

149 to 260°C: Requires addition of shaft cooler and high temperature grease bearings.

261 to 315°F: Above modifications plus high temperature aluminium paint.

316 to 426°F: Above modifications plus modified pedestal design.

ARRANGEMENTS

Arrangement 1

The usual choice for many V-belt drive applications. Impeller is overhung. Steel bearing pedestal to size 730. Size 800 requires concrete pedestal. Consult factory for V-belt drive applications larger than 200 kW.

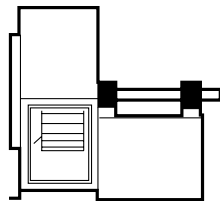

Arrangement 3SI

SWSI fan with integral inlet box and independent bearing pedestals. The impeller is supported between two bearings.

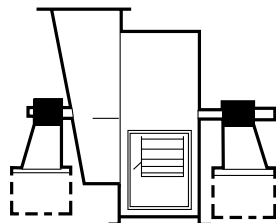

Arrangement 7SI

Direct coupled with a flexible coupling. A single-width, single-inlet fan with an integral inlet box and independent bearing pedestal and bearing/motor pedestal installed on a common base. The impeller is supported between two bearings.

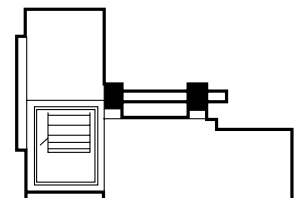

Arrangement 8

Direct coupled with a flexible coupling. The motor pedestal can be custom fabricated out of steel for up to 250 kW. On larger kW units, use of standard Arr. 1 fan with a concrete pedestal for the motor is advisable.

Arrangement 9F

Floor mount. Similar to Arrangement 1 with the fan base extended to mount motor in a horizontal position.

INLET BOXES

Typical Inlet Box Dimensions

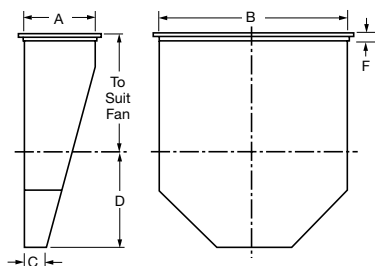

FAN SIZE	A	B	C	D	INLET AREA (m ²)	F
180	248	730	81	254	0.17	38 x 38
200	270	800	81	279	0.21	38 x 38
220	298	889	81	305	0.26	38 x 38
240	330	978	81	318	0.31	38 x 38
270	365	1080	81	356	0.38	38 x 38
300	403	1191	81	381	0.46	38 x 38
330	454	1324	81	419	0.57	51 x 51
360	492	1457	81	510	0.70	51 x 51
400	543	1610	81	556	0.85	64 x 64
450	594	1762	106	622	1.02	64 x 64
490	657	1953	106	678	1.26	64 x 64
540	724	2146	133	730	1.51	64 x 64
600	800	2375	133	784	1.86	76 x 76
660	886	2629	133	849	2.29	76 x 76
730	978	2908	159	940	2.79	89 x 89
800	1080	3213	159	1026	3.34	89 x 89

Dimensions are not to be used for construction. Dimensions are in mm unless otherwise noted.

Inlet Box Positions for Centrifugal Fans

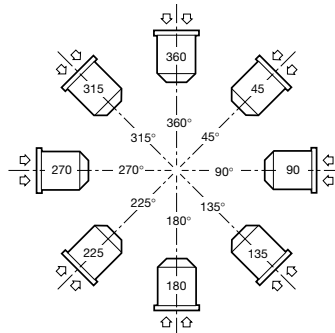

INLET BOX POSITIONS AND DESCRIPTIONS
45 — Angular Down Intake
90 — Horizontal Right Intake
135 — Angular Up Intake
180 — Bottom Up Intake
225 — Angular Up Intake
270 — Horizontal Left Intake
315 — Angular Down Intake
360 — Top Down Intake

Reference line is the Top Vertical Axis through center of fan shaft. Position of inlet box and air entry to inlet box is determined from drive side of fan.

Position of inlet box is designated in degrees clockwise from Top Vertical Axis as shown.

Positions 135° to 225° in some cases interfere seriously with floor structure.

Arrangement 1 fan with detached inlet box. Can be supplied in Arrangement 8.

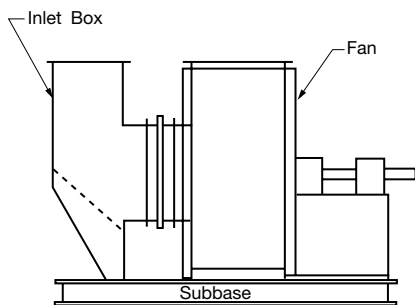

Arrangement 1 fan with attached or integral inlet box. Can be supplied in Arrangement 8.

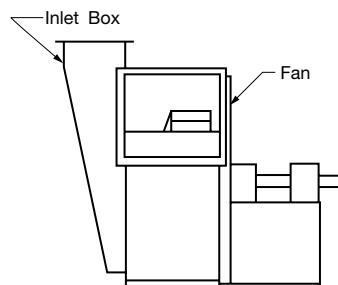

Arrangement 3SI fan with integral inlet box, centrally supported impeller, independent bearings pedestals to be installed on concrete pedestals.

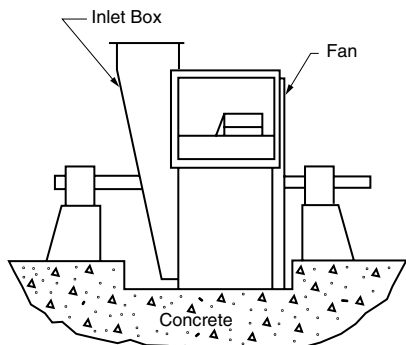

Arrangement 7SI — Similar to Arrangement 3SI except bearings pedestals and motor installed on a steel common base.

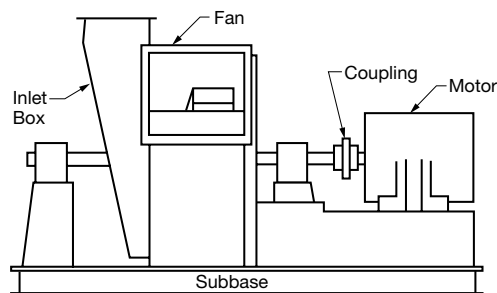

Table 1. Material and Mechanical Specifications

FAN SIZE	DESIGN RTF	SHAFT DIA.	MAX. kW V-BELT DRIVE	MIN. SHEAVE DIA. ¹	MAX. kW DIRECT DRIVE	MAX. RPM ²	WHEEL WT. (kg)	WHEEL			WR ² (kg-m ²)	HOUSING	ARR. 1 FAN WT. (kg)
								BACK PLATE	BLADES	SHROUD			
180	18	56	22.4	145	29.8	3342	26.8	6	3	3	0.9	5	338
	23	56	44.7	137	55.9	3971	31.8	8	3	3	0.9	5	345
200	18	56	29.8	168	55.9	3026	32.2	6	3	3	1.3	5	374
	23	62	55.9	150	74.6	3800	38.1	8	3	3	1.5	5	386
220	18	56	37.3	191	44.7	2723	39.5	6	3	3	1.9	5	397
	23	62	74.6	168	93.2	3484	46.7	8	3	3	2.3	5	422
240	18	56	44.7	213	55.9	2476	47.6	6	3	3	2.9	5	417
	23	68	93.2	183	111.9	3167	56.7	8	3	3	3.4	5	454
270	18	62	55.9	241	74.6	2264	58.1	8	3	3	3.8	5	499
	23	68	111.9	201	111.9	2892	69.4	8	3	3	4.7	5	526
300	18	68	74.6	282	111.9	2052	67.6	8	3	3	5.5	5	590
	23	75	149.1	221	149.1	2622	80.7	8	3	3	6.9	5	612
330	18	68	74.6	290	111.9	1858	88.9	8	3	3	8.2	5	694
	23	75	149.1	246	186.4	2374	104.8	8	3	3	10.2	5	717
360	18	75	111.9	320	111.9	1676	112.5	8	3	3	13.7	5	885
	23	87	186.4	290	223.7	2143	122.5	8	3	3	15.3	6	1057
400	18	87	149.1	307	149.1	1519	159.7	8	3	5	22.3	5	1111
	23	100	186.4	343	298.3	1942	183.7	10	3	5	26.8	6	1302
450	18	87	149.1	373	186.4	1375	185.1	8	3	5	32.8	5	1352
	23	100	186.4	292	372.8	1757	231.3	10	3	5	43.8	6	1606
490	18	100	186.4	361	223.7	1247	243.6	10	5	5	56.4	5	1719
	23	113	298.3	358	447.4	1573	302.5	13	5	5	73.1	6	1982
540	18	100	186.4	437	298.3	1127	342.9	10	5	6	89.9	5	2114
	23	113	298.3	442	522.0	1440	403.7	13	5	6	113.1	6	2486
600	18	113	223.7	450	298.3	1019	472.2	13	6	6	165.6	6	2885
	23	125	298.3	396	596.6	1302	502.6	13	6	6	179.6	6	2957
660	18	113	223.7	533	372.8	926	554.3	13	6	6	240.1	6	3302
	23	125	298.3	472	745.7	1183	690.4	16	6	6	308.0	6	3497
730	18	113	223.7	625	447.4	838	673.1	13	6	6	356.3	6	4010
	23	125	298.3	549	894.8	1071	837.8	16	6	6	462.8	6	4241
800 ³	18	125	298.3	653	522.0	758	802.4	13	6	6	531.1	6	3928
	23	138	298.3	498	1044.0	968	1005.2	16	6	6	689.9	6	4250

¹ Minimum fan diameter when using maximum kW motor. Check with the factory on applications over 250 kW.

² Maximum RPM shown are for 20°C. For higher temperatures use Table 2 on page 6 to derate RPM.

³ Size 800 RTF is not supplied with conventional bearings pedestal. Instead we supply channel sub-bases. The sub-base is to be mounted on concrete pedestal with steel sole plate in the field. Fan weights include weight of channel sub-base.

Dimensions are in millimeters unless otherwise noted.



Derating Factors For High Temperature

When elevated temperatures are encountered, the maximum RPM allowable as shown in Table 1 on page 5 must be derated according to the derating factors from Table 2. Standard steel construction is suitable for use in gas temperatures to 426°C. Aluminium impellers are suitable for temperatures to 120°C only.

Table 2. Temperature Derating Factors

TEMP. (°C)	DERATING FACTOR	
	STANDARD STEEL	STAINLESS STEEL
21	1.000	1.000
93	0.990	0.950
149	0.975	0.916
204	0.955	0.877
260	0.930	0.841
316	0.904	0.809
371	0.880	0.777
427	0.837	0.754

Performance Correction for Temperature and Altitude

The performance curves in this catalogue are based on fans handling standard air at a density of 1.2014 kilograms per cubic meter. This is equivalent to 20°C at sea level (759.968 mm Hg barometric pressure). When specified performance is at a density different than standard, it must be converted to the equivalent standard conditions before entering the performance curves. The equivalent conditions can be calculated by using the “Temperature and Altitude Density Ratios” table below.

Table 3. Temperature and Altitude Density Ratios

AIR TEMP °C	ALTITUDE IN METRES ABOVE SEA LEVEL											
	0	300	600	900	1200	1500	1750	2000	2500	3000	3500	4000
	BAROMETRIC PRESSURE IN mm Hg (Torr)											
	759.96	733.34	707.46	682.33	657.88	634.18	614.98	596.22	560.17	525.87	493.24	462.35
BAROMETRIC PRESSURE IN kPa												
101.32	97.77	94.32	90.97	87.71	84.55	81.99	79.49	74.68	70.11	65.76	61.64	
-40	1.257	1.213	1.170	1.129	1.088	1.049	1.017	0.986	0.927	0.87	0.816	0.765
-20	1.158	1.117	1.078	1.040	1.002	0.966	0.937	0.908	0.854	0.801	0.752	0.704
0	1.073	1.036	0.999	0.964	0.929	0.896	0.868	0.842	0.791	0.743	0.697	0.653
20	1.000	0.965	0.931	0.898	0.866	0.834	0.809	0.785	0.737	0.692	0.649	0.608
40	0.936	0.903	0.871	0.840	0.810	0.781	0.757	0.734	0.690	0.648	0.608	0.569
60	0.880	0.849	0.819	0.790	0.762	0.734	0.712	0.690	0.649	0.609	0.571	0.535
80	0.830	0.801	0.773	0.745	0.719	0.693	0.672	0.651	0.612	0.574	0.539	0.505
100	0.786	0.758	0.731	0.705	0.680	0.656	0.636	0.616	0.579	0.544	0.510	0.478
125	0.736	0.710	0.685	0.661	0.637	0.614	0.596	0.578	0.543	0.509	0.478	0.448
150	0.693	0.668	0.645	0.622	0.600	0.578	0.561	0.543	0.511	0.479	0.450	0.421
175	0.654	0.631	0.609	0.587	0.566	0.546	0.529	0.513	0.482	0.453	0.425	0.398
200	0.620	0.598	0.577	0.556	0.536	0.517	0.501	0.486	0.457	0.429	0.402	0.377
225	0.588	0.568	0.548	0.528	0.509	0.491	0.476	0.462	0.434	0.407	0.382	0.358
250	0.560	0.541	0.522	0.503	0.485	0.468	0.453	0.440	0.413	0.388	0.364	0.341
275	0.535	0.516	0.498	0.480	0.463	0.446	0.433	0.420	0.394	0.370	0.347	0.325
300	0.511	0.494	0.476	0.459	0.443	0.427	0.414	0.401	0.377	0.354	0.332	0.311
350	0.470	0.454	0.438	0.422	0.407	0.393	0.381	0.369	0.347	0.326	0.305	0.286
375	0.452	0.436	0.421	0.406	0.392	0.377	0.366	0.355	0.333	0.313	0.294	0.275
400	0.435	0.420	0.405	0.391	0.377	0.363	0.352	0.342	0.321	0.301	0.283	0.265
425	0.420	0.405	0.391	0.377	0.363	0.350	0.340	0.329	0.309	0.291	0.273	0.255
450	0.405	0.391	0.377	0.364	0.351	0.338	0.328	0.318	0.299	0.280	0.263	0.247
500	0.379	0.366	0.353	0.340	0.328	0.316	0.307	0.297	0.279	0.262	0.246	0.231
550	0.356	0.344	0.332	0.320	0.308	0.297	0.288	0.279	0.262	0.246	0.231	0.217



RTF 180

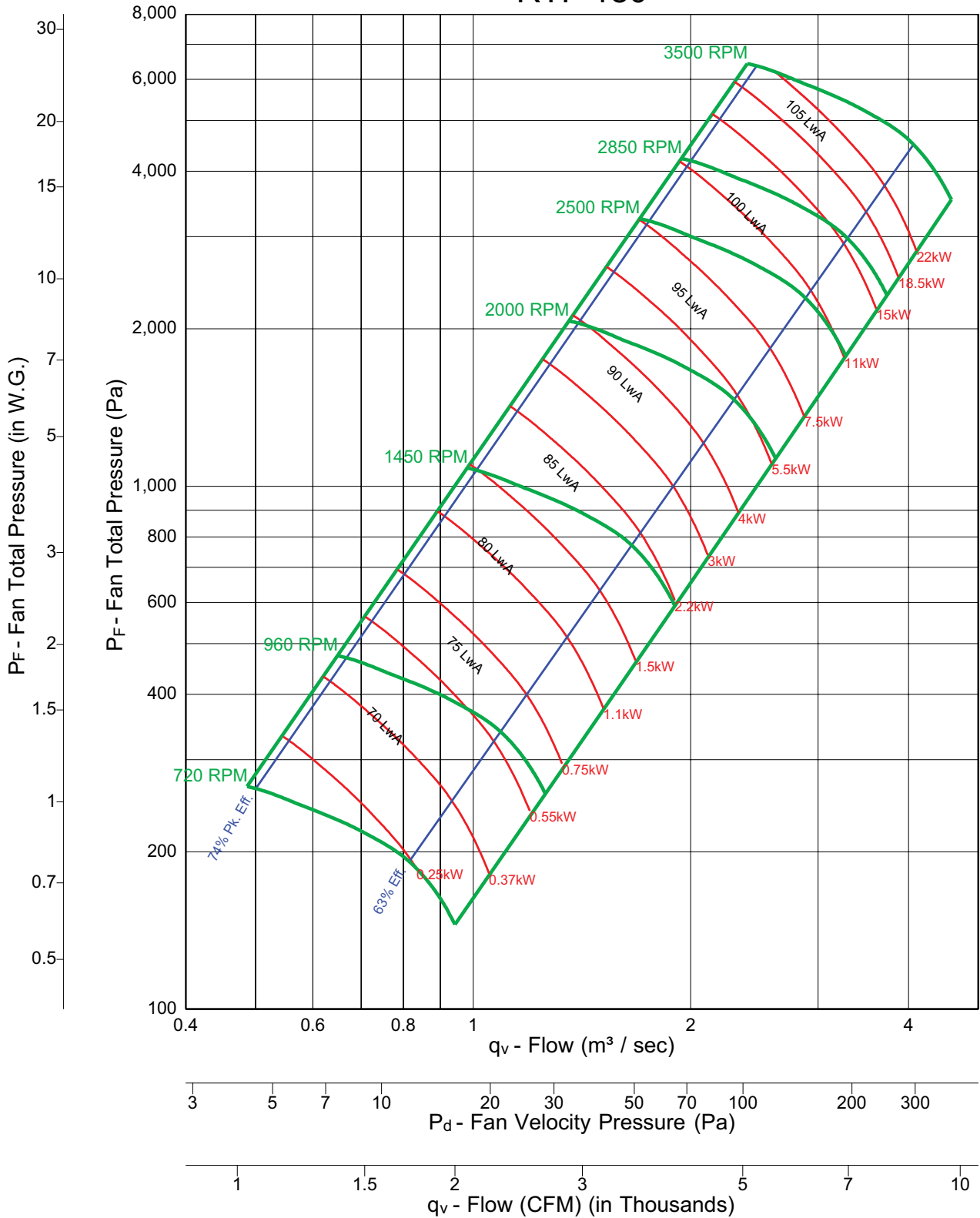

Fan Efficiency Grade = FEG 80

Notes:

1. Performance certified is for Installation Type B & D: Free or ducted inlet, ducted outlet.
2. Power rating (kW) does not include transmission losses.
3. Performance ratings do not include the effects of appurtenances (accessories).
4. The sound power level ratings shown are in decibels, referred to 10 E-12 watts calculated per AMCA Standard 301.
5. Values shown are for inlet LwIA sound power levels for Installation Type B: Free inlet, ducted outlet.
6. Ratings do not include the effects of duct end correction.
7. The A-weighted sound ratings shown have been calculated per AMCA Standard 301.

RTF 200

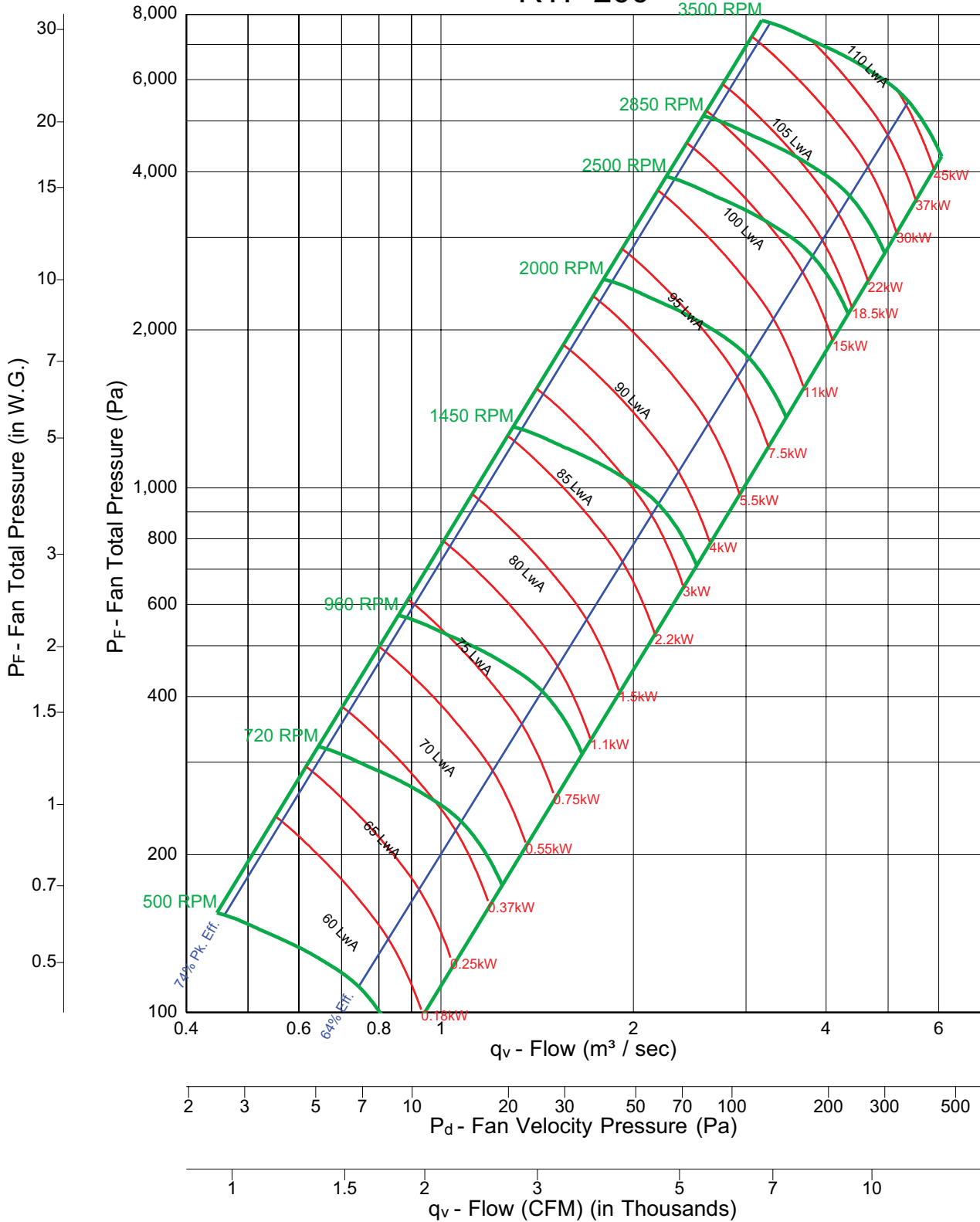

Fan Efficiency Grade = FEG 80

Notes:

1. Performance certified is for Installation Type B & D: Free or ducted inlet, ducted outlet.
2. Power rating (kW) does not include transmission losses.
3. Performance ratings do not include the effects of appurtenances (accessories).
4. The sound power level ratings shown are in decibels, referred to 10 E-12 watts calculated per AMCA Standard 301.
5. Values shown are for inlet LwA sound power levels for Installation Type B: Free inlet, ducted outlet.
6. Ratings do not include the effects of duct end correction.
7. The A-weighted sound ratings shown have been calculated per AMCA Standard 301.

RTF 220

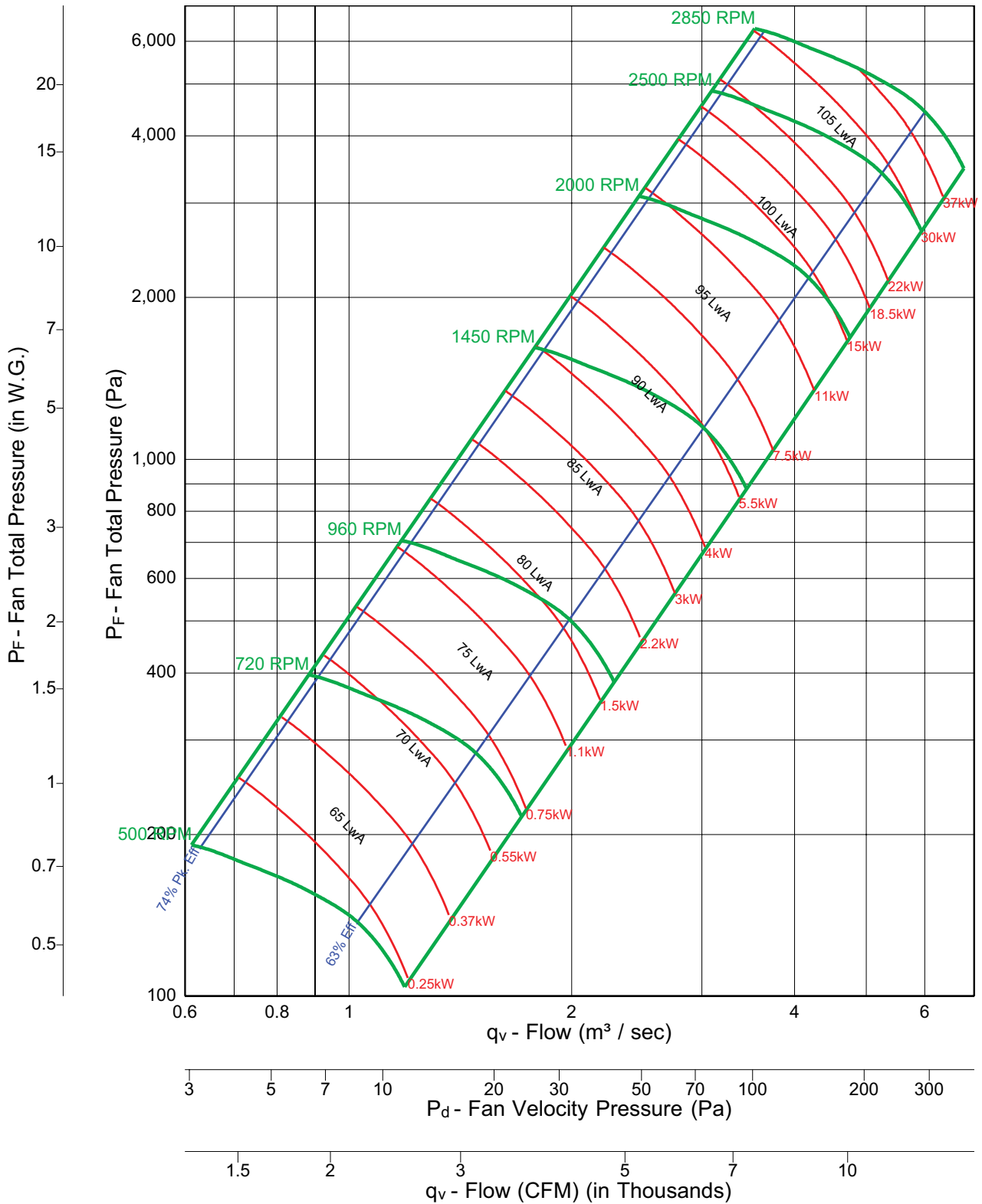

Fan Efficiency Grade = FEG 75

Notes:

1. Performance certified is for Installation Type B & D: Free or ducted inlet, ducted outlet.
2. Power rating (kW) does not include transmission losses.
3. Performance ratings do not include the effects of appurtenances (accessories).
4. The sound power level ratings shown are in decibels, referred to 10 E-12 watts calculated per AMCA Standard 301.
5. Values shown are for inlet LwA sound power levels for Installation Type B: Free inlet, ducted outlet.
6. Ratings do not include the effects of duct end correction.
7. The A-weighted sound ratings shown have been calculated per AMCA Standard 301.

RTF 240

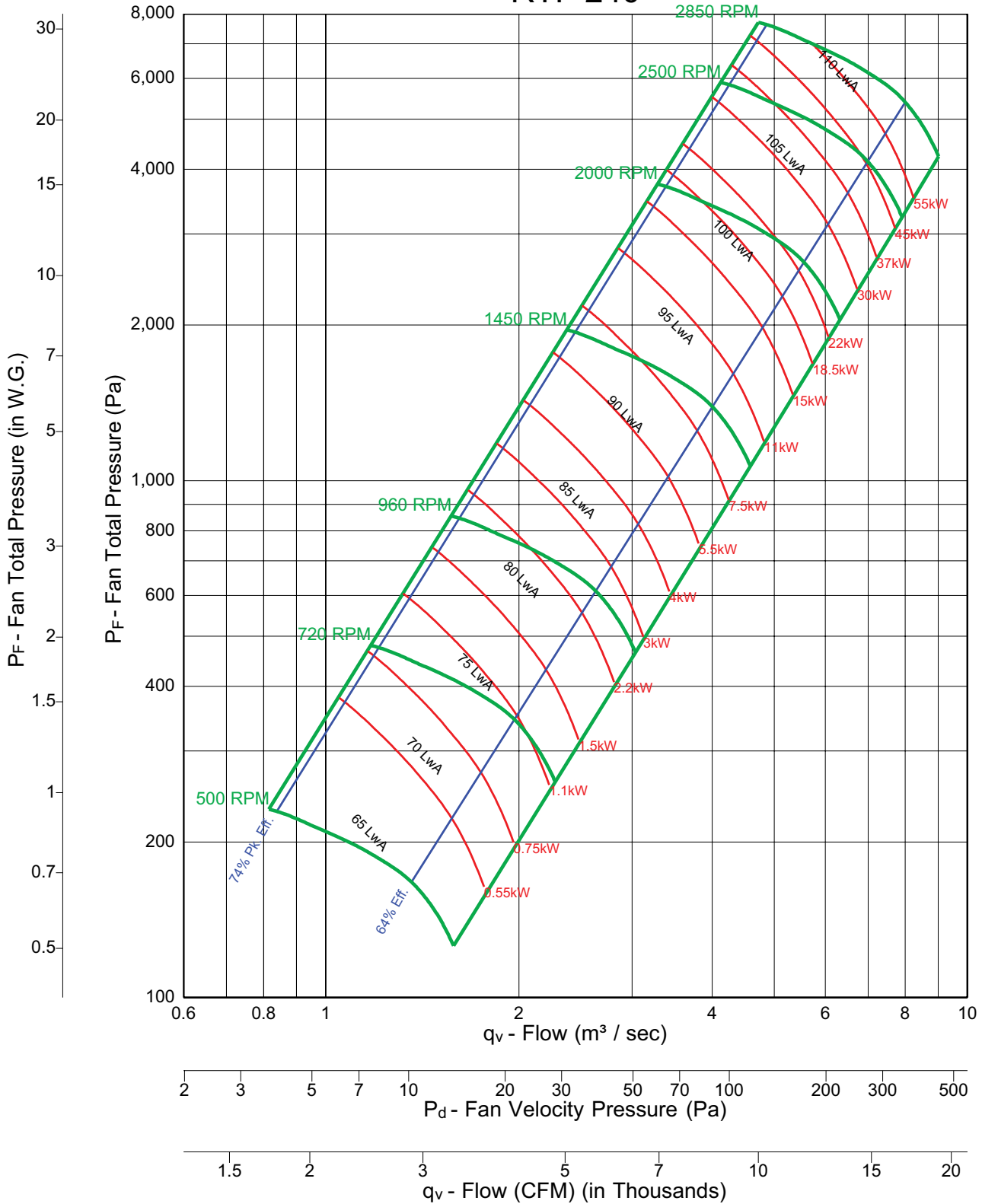

Fan Efficiency Grade = FEG 75

Notes:

1. Performance certified is for Installation Type B & D: Free or ducted inlet, ducted outlet.
2. Power rating (kW) does not include transmission losses.
3. Performance ratings do not include the effects of appurtenances (accessories).
4. The sound power level ratings shown are in decibels, referred to 10 E-12 watts calculated per AMCA Standard 301.
5. Values shown are for inlet LwA sound power levels for Installation Type B: Free inlet, ducted outlet.
6. Ratings do not include the effects of duct end correction.
7. The A-weighted sound ratings shown have been calculated per AMCA Standard 301.

RTF 270

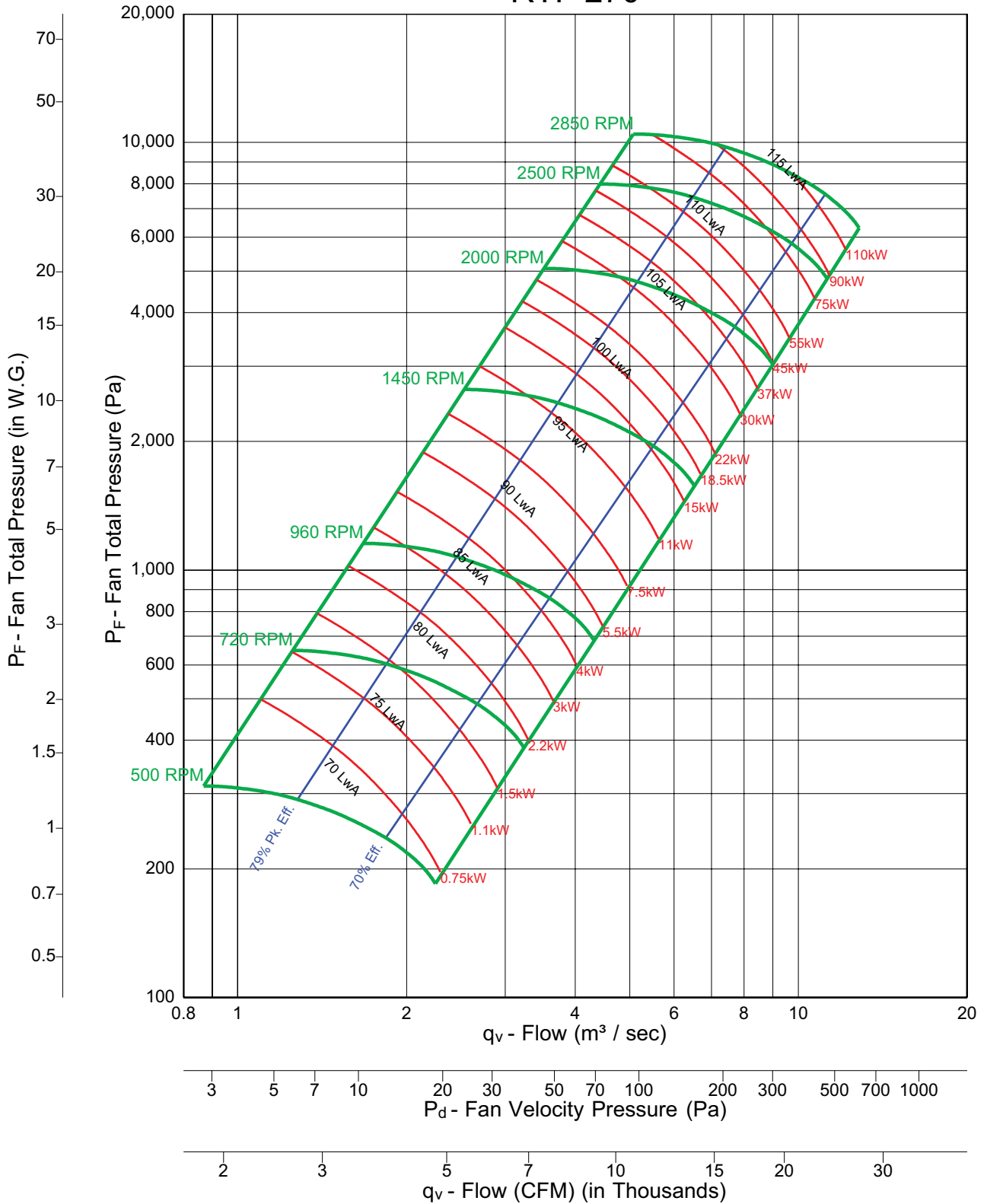

Fan Efficiency Grade = FEG 80



Notes:

1. Performance certified is for Installation Type B & D: Free or ducted inlet, ducted outlet.
2. Power rating (kW) does not include transmission losses.
3. Performance ratings do not include the effects of appurtenances (accessories).
4. The sound power level ratings shown are in decibels, referred to 10 E-12 watts calculated per AMCA Standard 301.
5. Values shown are for inlet LwA sound power levels for Installation Type B: Free inlet, ducted outlet.
6. Ratings do not include the effects of duct end correction.
7. The A-weighted sound ratings shown have been calculated per AMCA Standard 301.

RTF 300

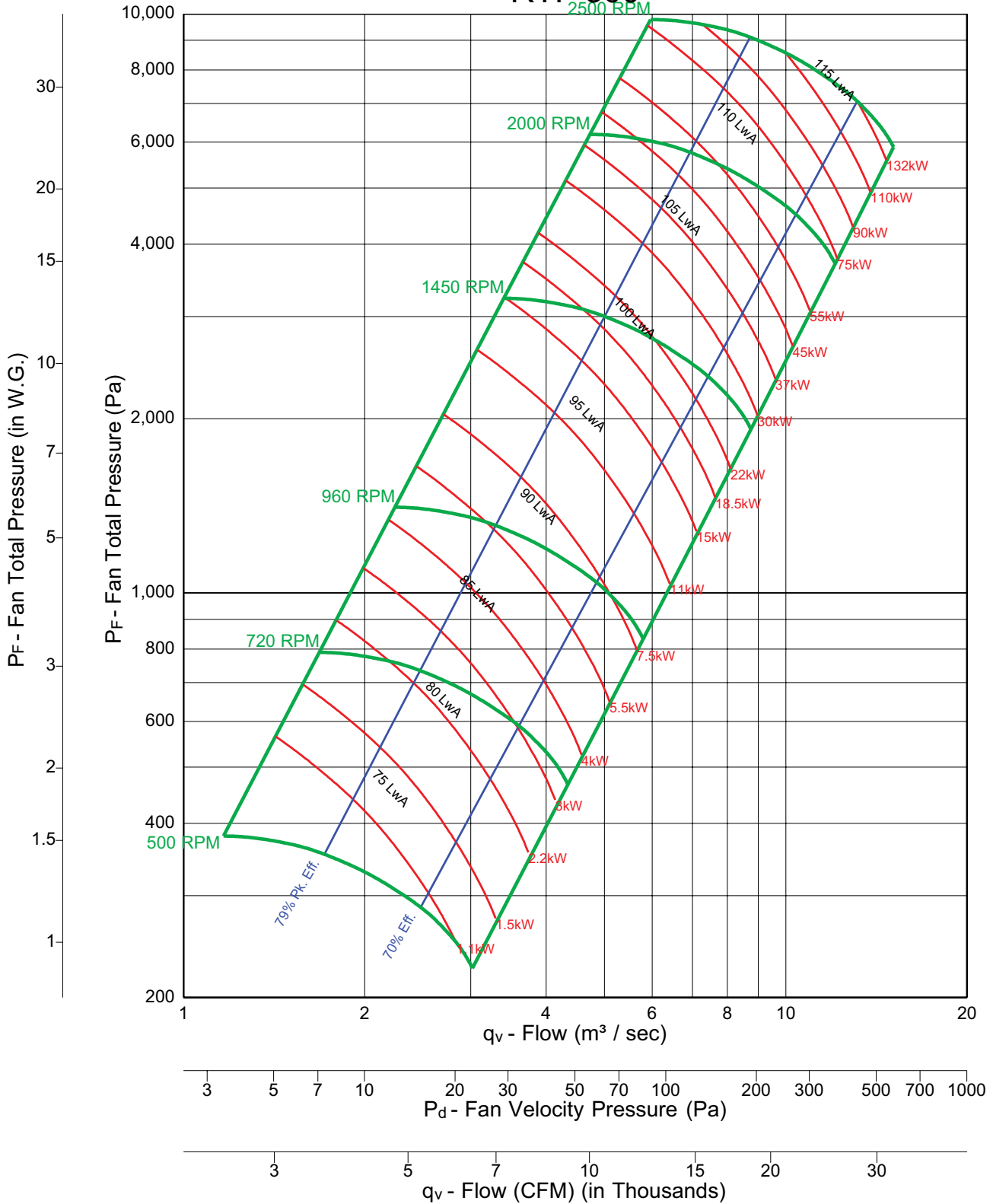

Fan Efficiency Grade = FEG 80



Notes:

1. Performance certified is for Installation Type B & D: Free or ducted inlet, ducted outlet.
2. Power rating (kW) does not include transmission losses.
3. Performance ratings do not include the effects of appurtenances (accessories).
4. The sound power level ratings shown are in decibels, referred to 10 E-12 watts calculated per AMCA Standard 301.
5. Values shown are for inlet LwA sound power levels for Installation Type B: Free inlet, ducted outlet.
6. Ratings do not include the effects of duct end correction.
7. The A-weighted sound ratings shown have been calculated per AMCA Standard 301.

RTF 330

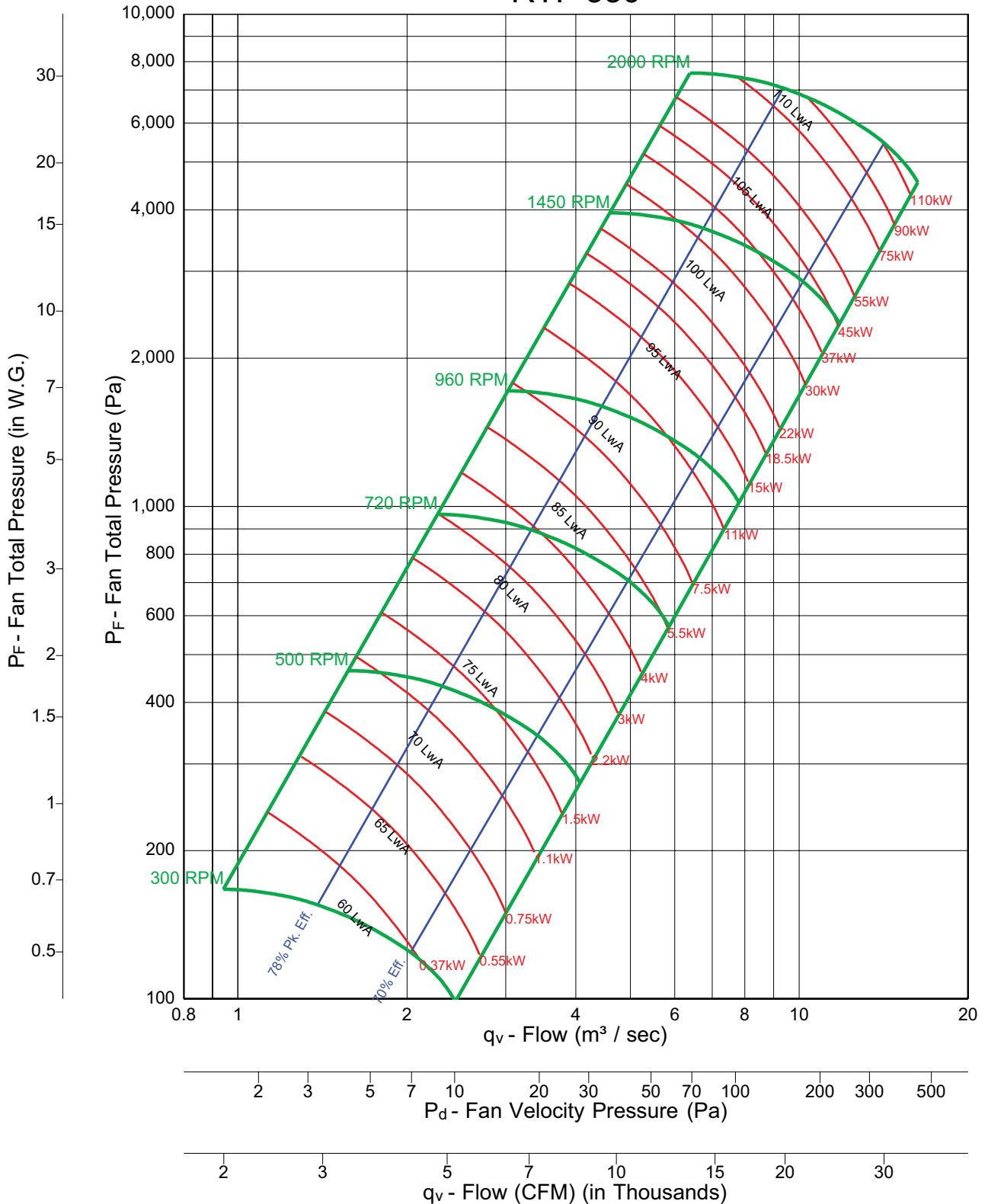

Fan Efficiency Grade = FEG 80



Notes:

1. Performance certified is for Installation Type B & D: Free or ducted inlet, ducted outlet.
2. Power rating (kW) does not include transmission losses.
3. Performance ratings do not include the effects of appurtenances (accessories).
4. The sound power level ratings shown are in decibels, referred to 10 E-12 watts calculated per AMCA Standard 301.
5. Values shown are for inlet LwA sound power levels for Installation Type B: Free inlet, ducted outlet.
6. Ratings do not include the effects of duct end correction.
7. The A-weighted sound ratings shown have been calculated per AMCA Standard 301.

RTF 360

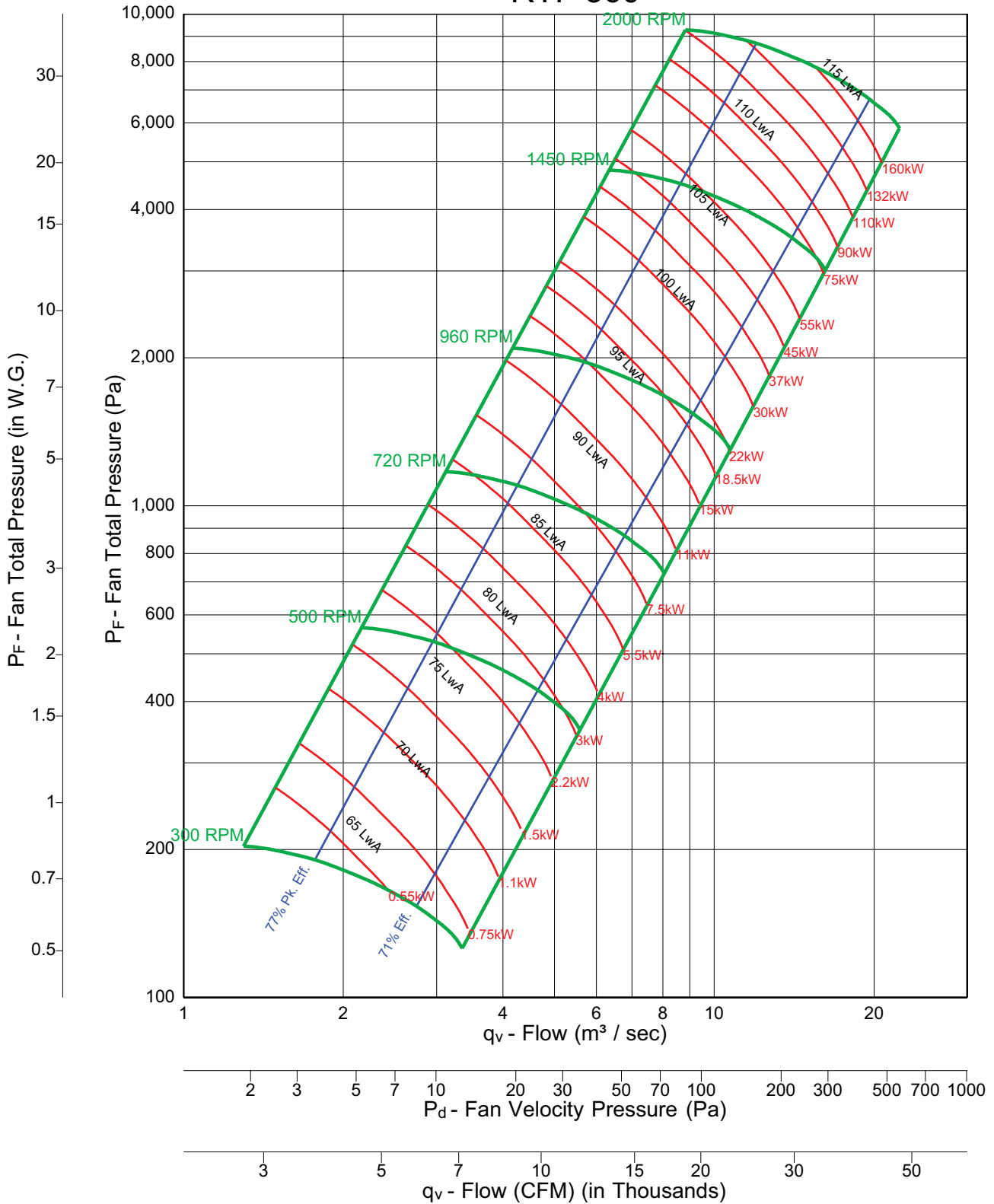

Fan Efficiency Grade = FEG 80



Notes:

1. Performance certified is for Installation Type B & D: Free or ducted inlet, ducted outlet.
2. Power rating (kW) does not include transmission losses.
3. Performance ratings do not include the effects of appurtenances (accessories).
4. The sound power level ratings shown are in decibels, referred to 10 E-12 watts calculated per AMCA Standard 301.
5. Values shown are for inlet LwA sound power levels for Installation Type B: Free inlet, ducted outlet.
6. Ratings do not include the effects of duct end correction.
7. The A-weighted sound ratings shown have been calculated per AMCA Standard 301.

RTF 400

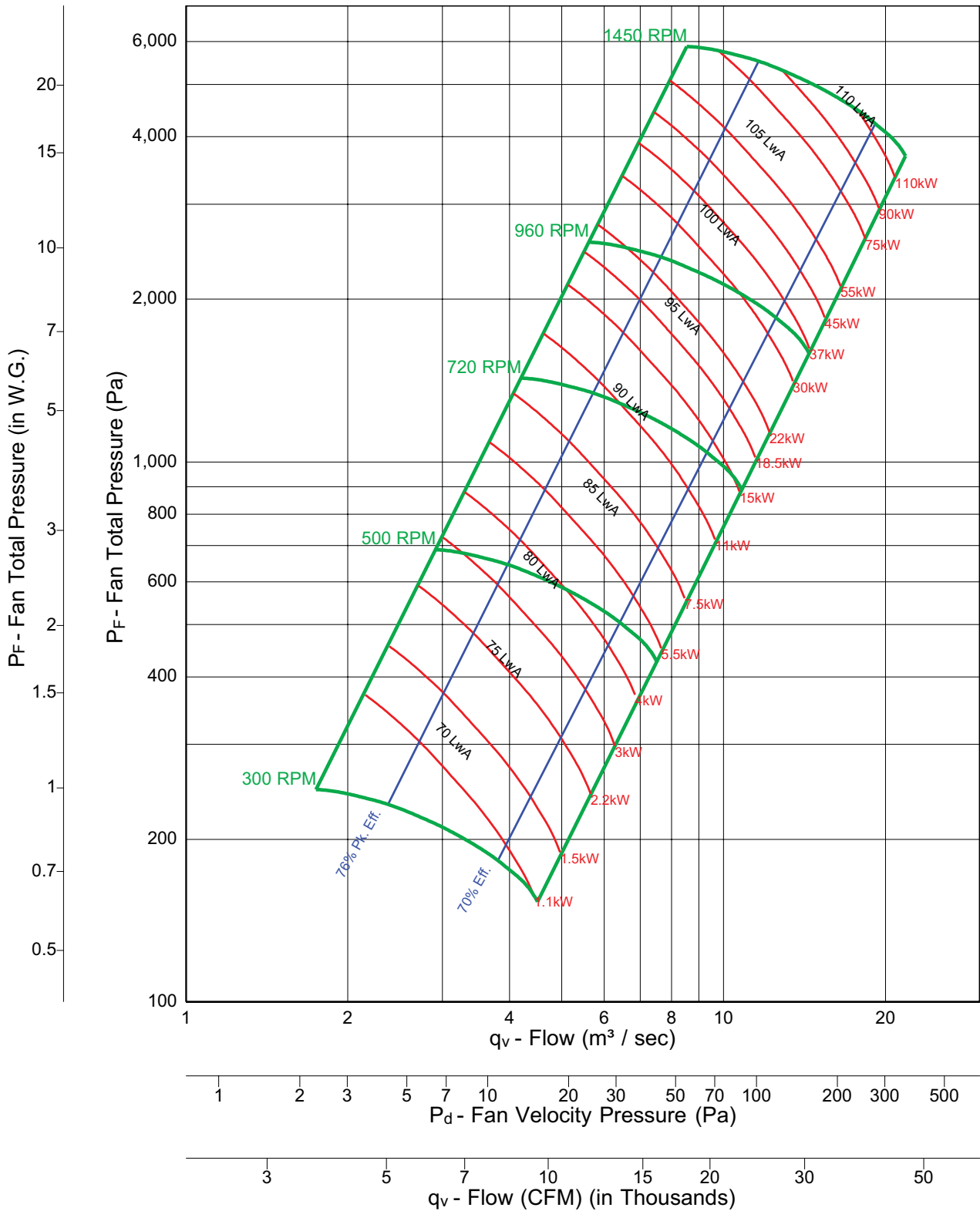

Fan Efficiency Grade = FEG 80



Notes:

1. Performance certified is for Installation Type B & D: Free or ducted inlet, ducted outlet.
2. Power rating (kW) does not include transmission losses.
3. Performance ratings do not include the effects of appurtenances (accessories).
4. The sound power level ratings shown are in decibels, referred to 10 E-12 watts calculated per AMCA Standard 301.
5. Values shown are for inlet LwA sound power levels for Installation Type B: Free inlet, ducted outlet.
6. Ratings do not include the effects of duct end correction.
7. The A-weighted sound ratings shown have been calculated per AMCA Standard 301.

RTF 450

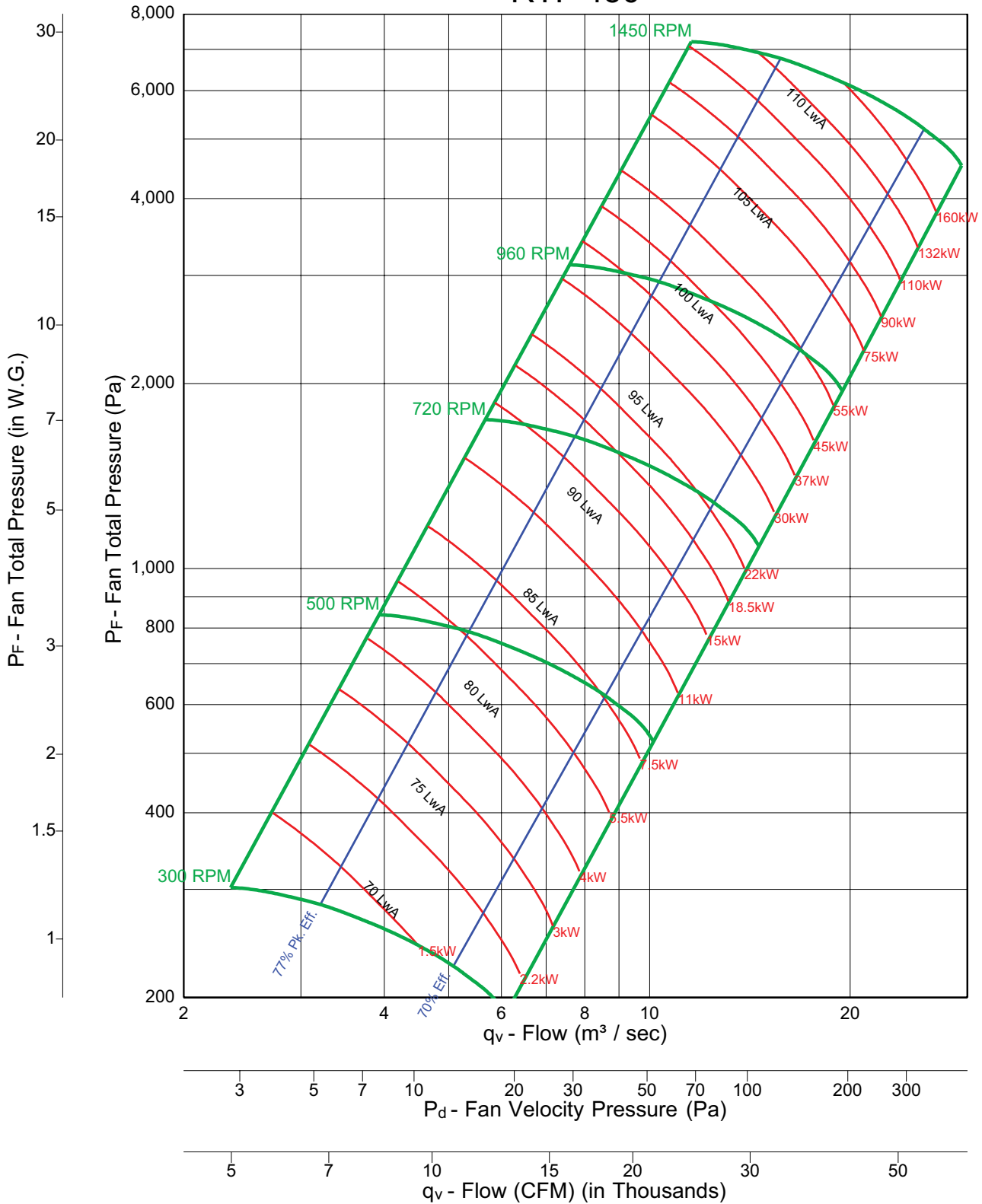

Fan Efficiency Grade = FEG 80



Notes:

1. Performance certified is for Installation Type B & D: Free or ducted inlet, ducted outlet.
2. Power rating (kW) does not include transmission losses.
3. Performance ratings do not include the effects of appurtenances (accessories).
4. The sound power level ratings shown are in decibels, referred to 10 E-12 watts calculated per AMCA Standard 301.
5. Values shown are for inlet LwA sound power levels for Installation Type B: Free inlet, ducted outlet.
6. Ratings do not include the effects of duct end correction.
7. The A-weighted sound ratings shown have been calculated per AMCA Standard 301.

RTF 490

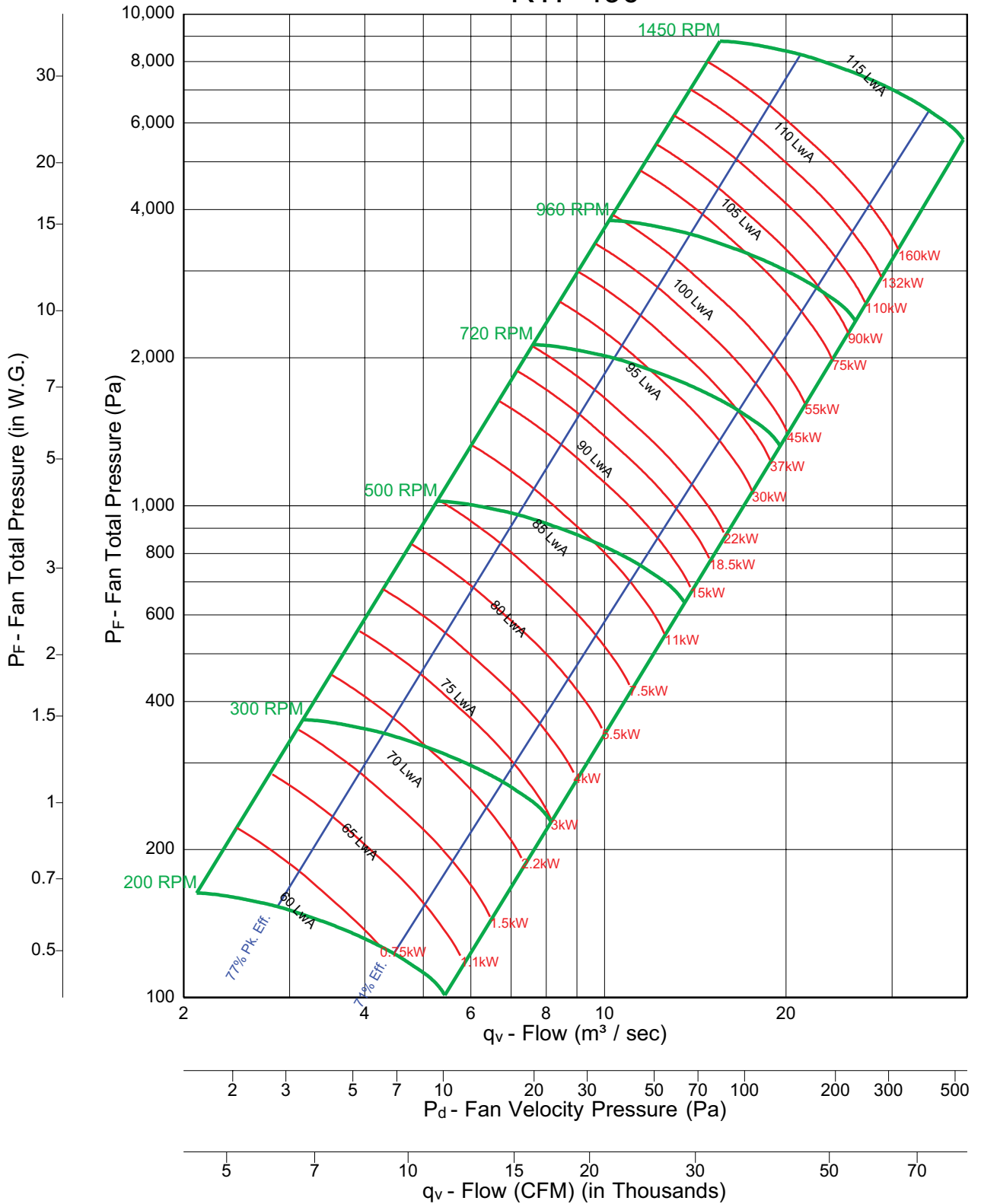

Fan Efficiency Grade = FEG 80



Notes:

1. Performance certified is for Installation Type B & D: Free or ducted inlet, ducted outlet.
2. Power rating (kW) does not include transmission losses.
3. Performance ratings do not include the effects of appurtenances (accessories).
4. The sound power level ratings shown are in decibels, referred to 10 E-12 watts calculated per AMCA Standard 301.
5. Values shown are for inlet LwA sound power levels for Installation Type B: Free inlet, ducted outlet.
6. Ratings do not include the effects of duct end correction.
7. The A-weighted sound ratings shown have been calculated per AMCA Standard 301.

RTF 540

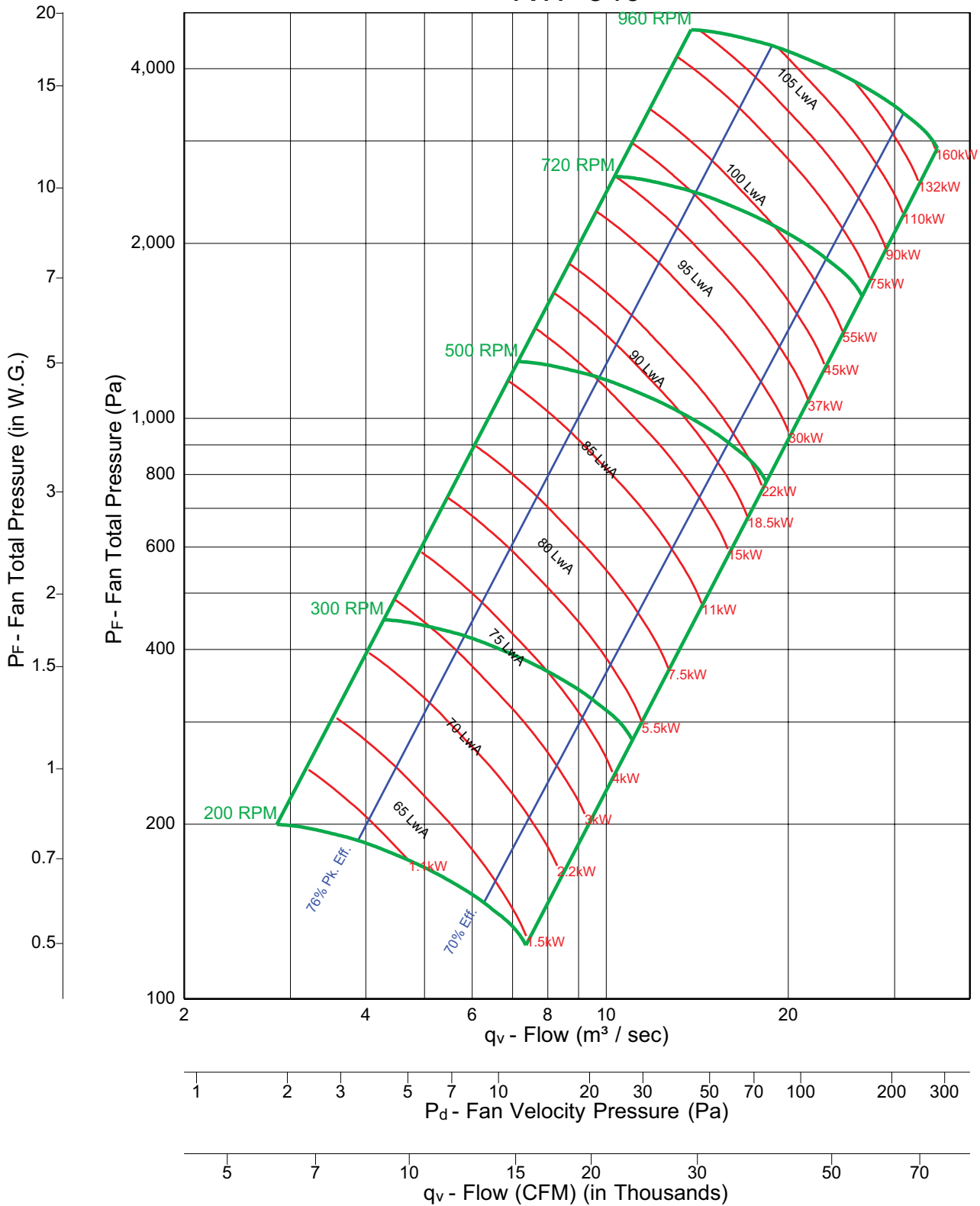

Fan Efficiency Grade = FEG 80



Notes:

1. Performance certified is for Installation Type B & D: Free or ducted inlet, ducted outlet.
2. Power rating (kW) does not include transmission losses.
3. Performance ratings do not include the effects of appurtenances (accessories).
4. The sound power level ratings shown are in decibels, referred to 10 E-12 watts calculated per AMCA Standard 301.
5. Values shown are for inlet LwIA sound power levels for Installation Type B: Free inlet, ducted outlet.
6. Ratings do not include the effects of duct end correction.
7. The A-weighted sound ratings shown have been calculated per AMCA Standard 301.

RTF 600

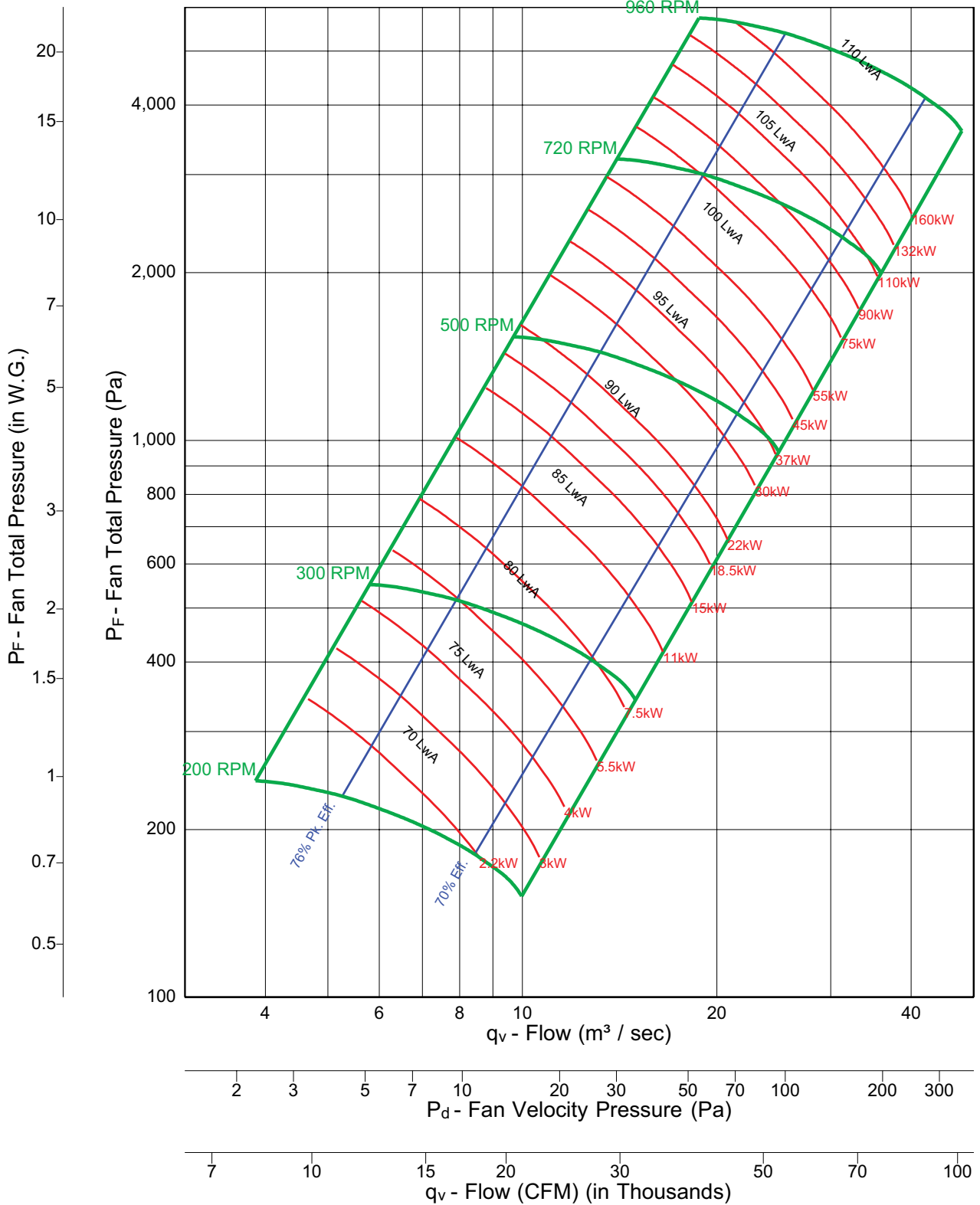

Fan Efficiency Grade = FEG 80



Notes:

1. Performance certified is for Installation Type B & D: Free or ducted inlet, ducted outlet.
2. Power rating (kW) does not include transmission losses.
3. Performance ratings do not include the effects of appurtenances (accessories).
4. The sound power level ratings shown are in decibels, referred to 10 E-12 watts calculated per AMCA Standard 301.
5. Values shown are for inlet LwA sound power levels for Installation Type B: Free inlet, ducted outlet.
6. Ratings do not include the effects of duct end correction.
7. The A-weighted sound ratings shown have been calculated per AMCA Standard 301.

RTF 660

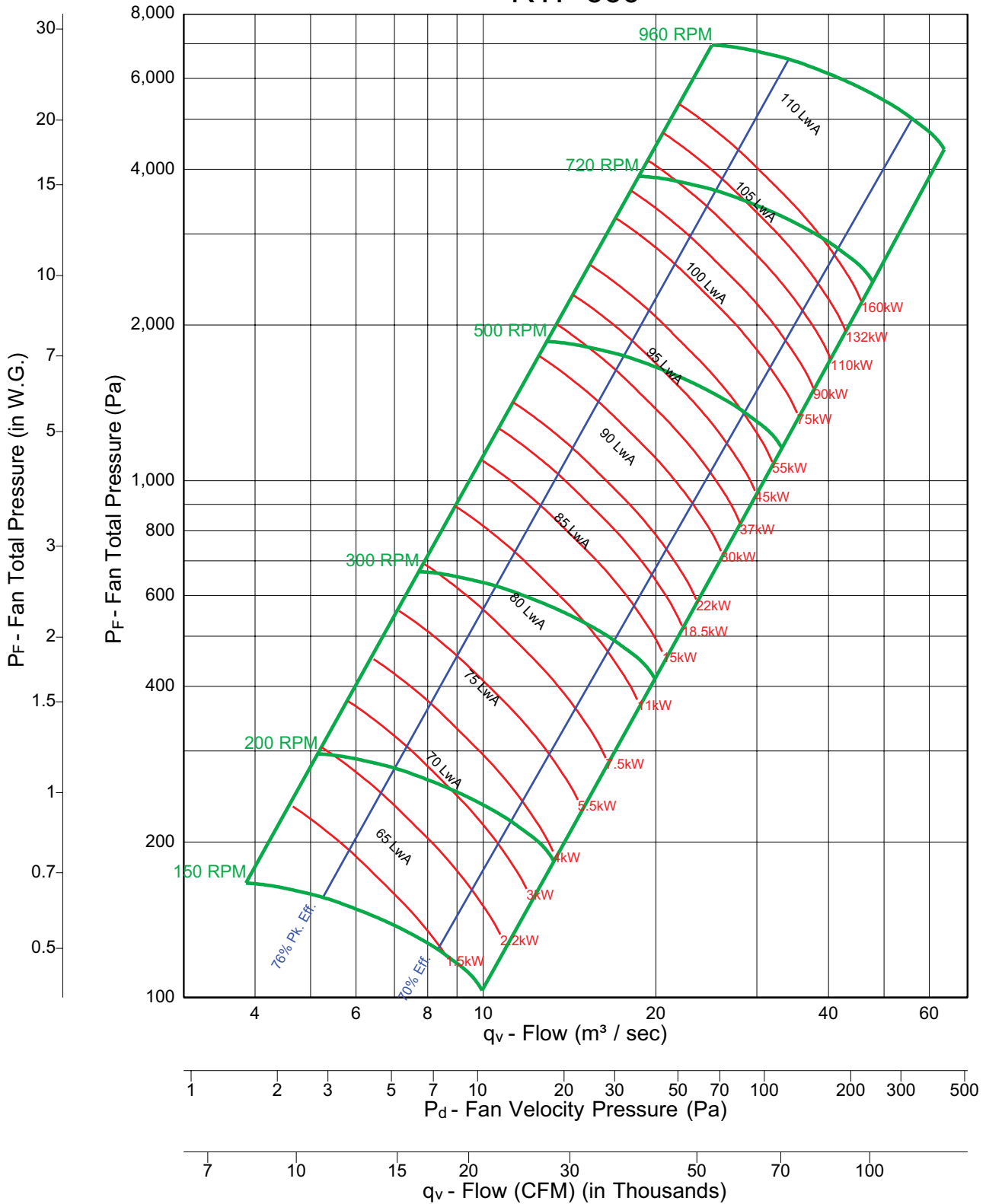

Fan Efficiency Grade = FEG 80



Notes:

1. Performance certified is for Installation Type B & D: Free or ducted inlet, ducted outlet.
2. Power rating (kW) does not include transmission losses.
3. Performance ratings do not include the effects of appurtenances (accessories).
4. The sound power level ratings shown are in decibels, referred to 10 E-12 watts calculated per AMCA Standard 301.
5. Values shown are for inlet LwA sound power levels for Installation Type B: Free inlet, ducted outlet.
6. Ratings do not include the effects of duct end correction.
7. The A-weighted sound ratings shown have been calculated per AMCA Standard 301.

RTF 730

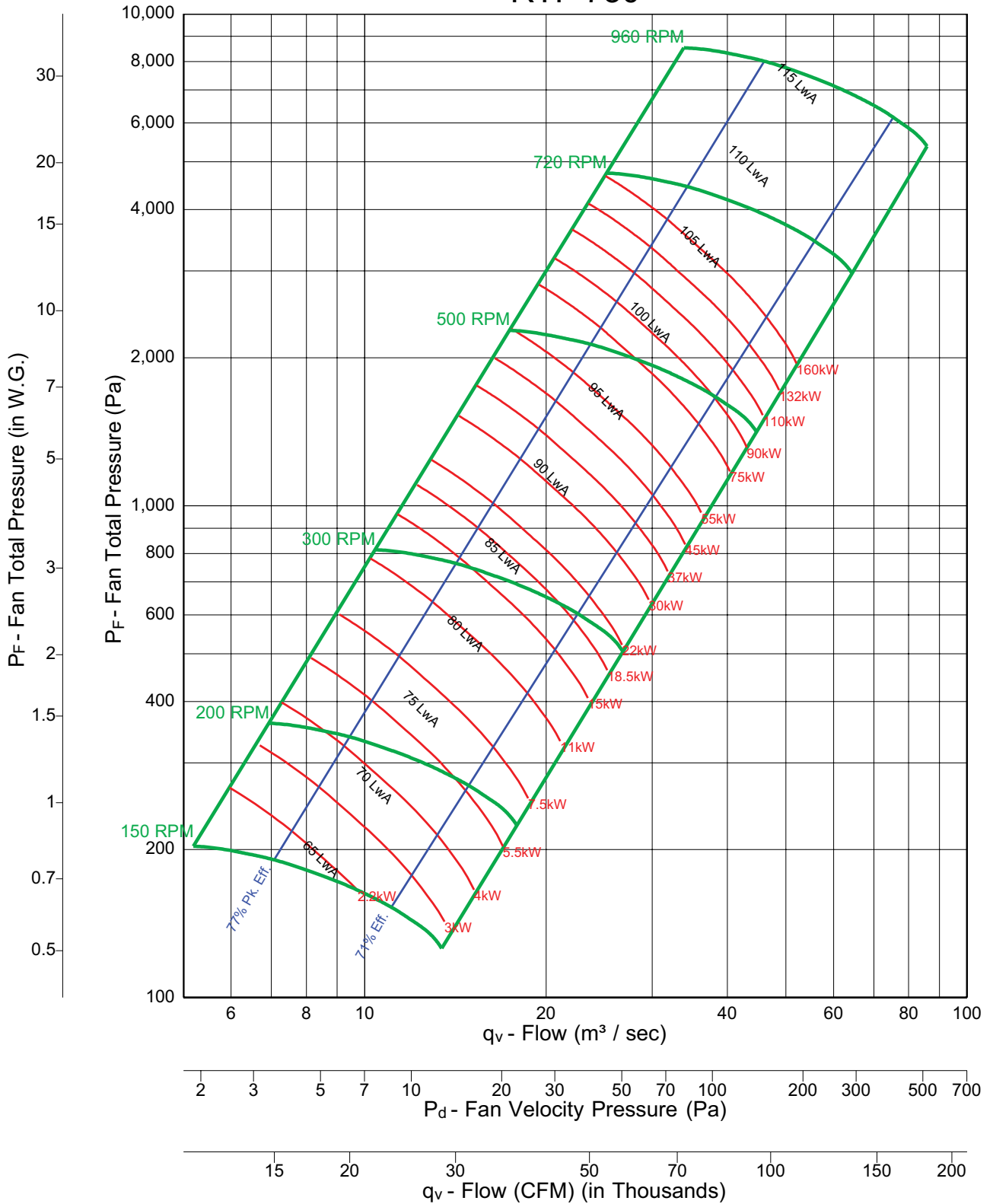

Fan Efficiency Grade = FEG 80



Notes:

1. Performance certified is for Installation Type B & D: Free or ducted inlet, ducted outlet.
2. Power rating (kW) does not include transmission losses.
3. Performance ratings do not include the effects of appurtenances (accessories).
4. The sound power level ratings shown are in decibels, referred to 10 E-12 watts calculated per AMCA Standard 301.
5. Values shown are for inlet LwA sound power levels for Installation Type B: Free inlet, ducted outlet.
6. Ratings do not include the effects of duct end correction.
7. The A-weighted sound ratings shown have been calculated per AMCA Standard 301.

RTF 800

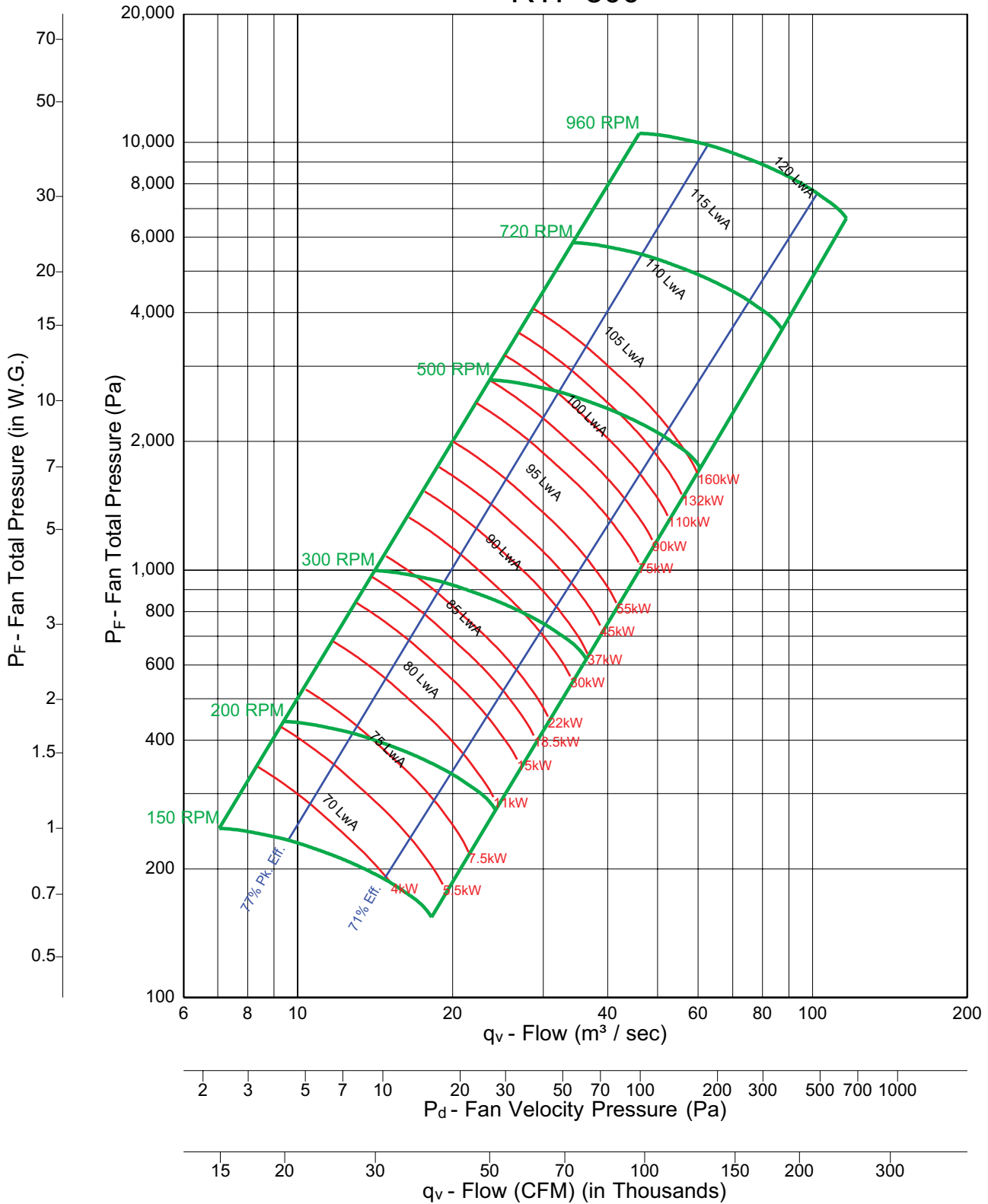

Fan Efficiency Grade = FEG 80



Notes:

1. Performance certified is for Installation Type B & D: Free or ducted inlet, ducted outlet.
2. Power rating (kW) does not include transmission losses.
3. Performance ratings do not include the effects of appurtenances (accessories).
4. The sound power level ratings shown are in decibels, referred to 10 E-12 watts calculated per AMCA Standard 301.
5. Values shown are for inlet LwA sound power levels for Installation Type B: Free inlet, ducted outlet.
6. Ratings do not include the effects of duct end correction.
7. The A-weighted sound ratings shown have been calculated per AMCA Standard 301.

Inlet Flange

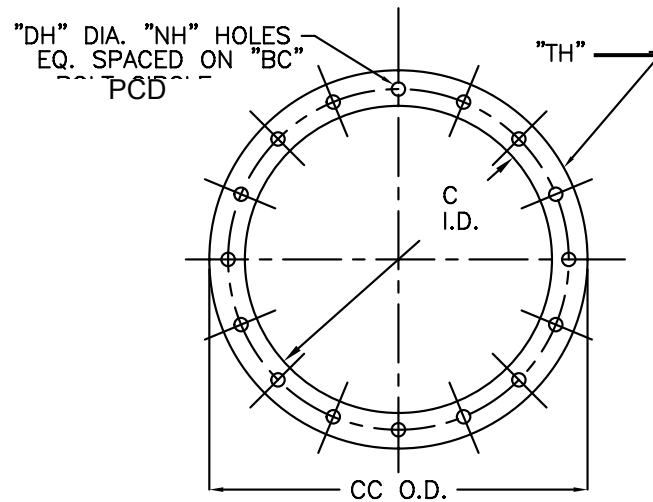

INLET FLANGE
DETAIL

FAN SIZE	BC	C	CC	DH	NH	TH
180	457	400	502	14	12	5
200	502	445	546	14	12	5
220	546	489	591	14	12	5
240	591	533	635	14	16	5
270	654	597	699	14	16	5
300	711	654	756	14	16	5
330	781	724	826	14	16	5
360	857	803	905	14	24	5
400	940	886	988	14	32	5
450	1032	978	1080	14	32	5
490	1168	1080	1232	18	40	6
540	1283	1194	1346	18	40	6
600	1410	1321	1473	18	40	6
660	1543	1454	1607	18	40	6
730	1721	1607	1810	18	48	8
800	1892	1778	1981	18	48	8



Arrangement 1, SWSI

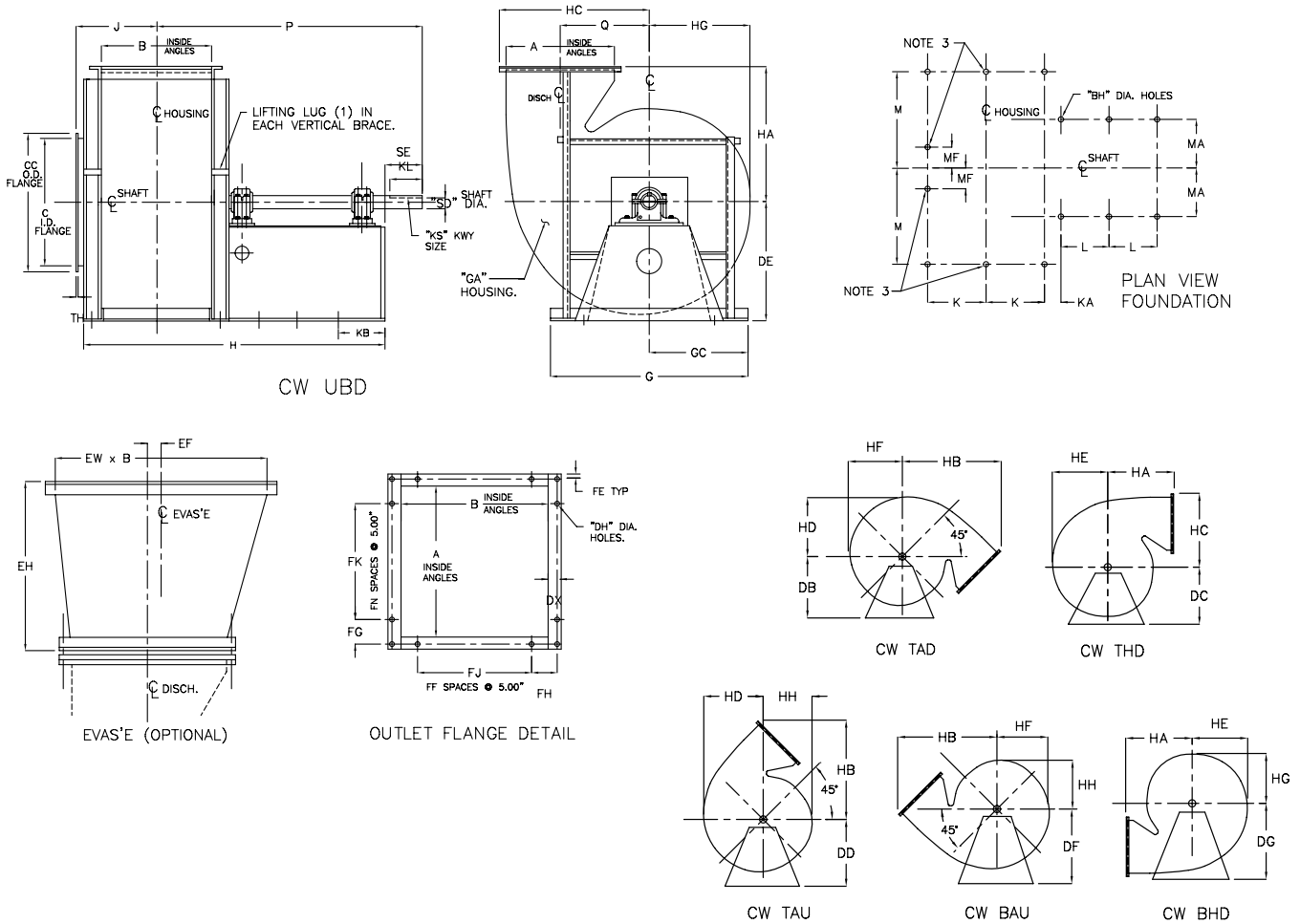

FAN SIZE	A	B	BC	BH	C	CC	DB CC	DD DE	DF DG	DH	DX	EF	EH	EW	FE	FF	FG	FH	FJ	FK	FN	G	GA
180	376	305	457	21	400	502	381	438	527	14	38	83	457	603	16	2	83	48	254	254	2	791	5
200	411	333	502	21	445	546	432	476	572	14	38	93	495	660	16	2	101	62	254	254	2	851	5
220	456	370	546	21	489	591	470	527	629	14	38	106	552	743	16	2	123	80	254	254	2	914	5
240	500	406	591	21	533	635	514	572	686	14	38	118	610	819	16	2	145	98	254	254	2	975	5
270	552	448	654	21	597	699	572	635	794	14	38	134	667	906	16	2	108	119	254	381	3	1086	5
300	608	492	711	21	654	756	629	699	864	14	38	148	737	999	16	3	136	78	381	381	3	1200	5
330	670	543	781	21	724	826	686	762	953	14	51	163	813	1103	22	3	110	110	381	508	4	1289	5

FAN SIZE	GC	H	HA	HB	HC	HD	HE	HF	HG	HH	J	K	KA	KB	KL	KS		L	M	MA	MF	NH
																CL 18	CL 24					
180	395	991	452	676	506	414	394	371	351	329	259	194	86	51	152	13 x 6	13 x 6	216	360	216	—	12
200	425	1045	495	740	552	454	430	406	384	360	273	208	86	51	165	13 x 6	16 x 8	229	391	241	—	12
220	457	1121	549	818	608	503	478	451	425	400	292	227	111	51	178	13 x 6	16 x 8	235	422	279	—	12
240	487	1181	602	895	665	554	525	497	468	440	310	244	111	51	178	13 x 6	16 x 8	248	452	305	—	16
270	543	1254	664	986	730	611	579	549	516	486	330	265	130	51	191	16 x 8	16 x 8	254	508	356	165	16
300	600	1330	730	1083	802	675	640	605	570	537	352	287	162	51	203	16 x 8	19 x 10	254	565	368	187	16
330	645	1407	806	1202	892	745	706	668	630	592	378	313	187	51	210	16 x 8	19 x 10	254	610	381	203	16

FAN SIZE	P	Q	SD		SE
			CL 18	CL 24	
180	940	281	56	56	178
200	992	310	56	62	191
220	1062	343	56	62	203
240	1105	378	56	68	203
270	1164	416	62	68	210
300	1230	460	68	75	222
330	1287	506	68	75	229

NOTES:

1. CW rotation shown, CCW rotation is similar but opposite.
2. Standard accessories: bolted access door, housing drain, shaft seal, punched inlet & outlet flanges.
3. These holes are in Size 270, 300 & 330 Only.

BC9987D

DIMENSIONS ARE NOT TO BE USED FOR CONSTRUCTION. CERTIFIED DRAWINGS AVAILABLE UPON REQUEST.

Arrangement 1, SWSI

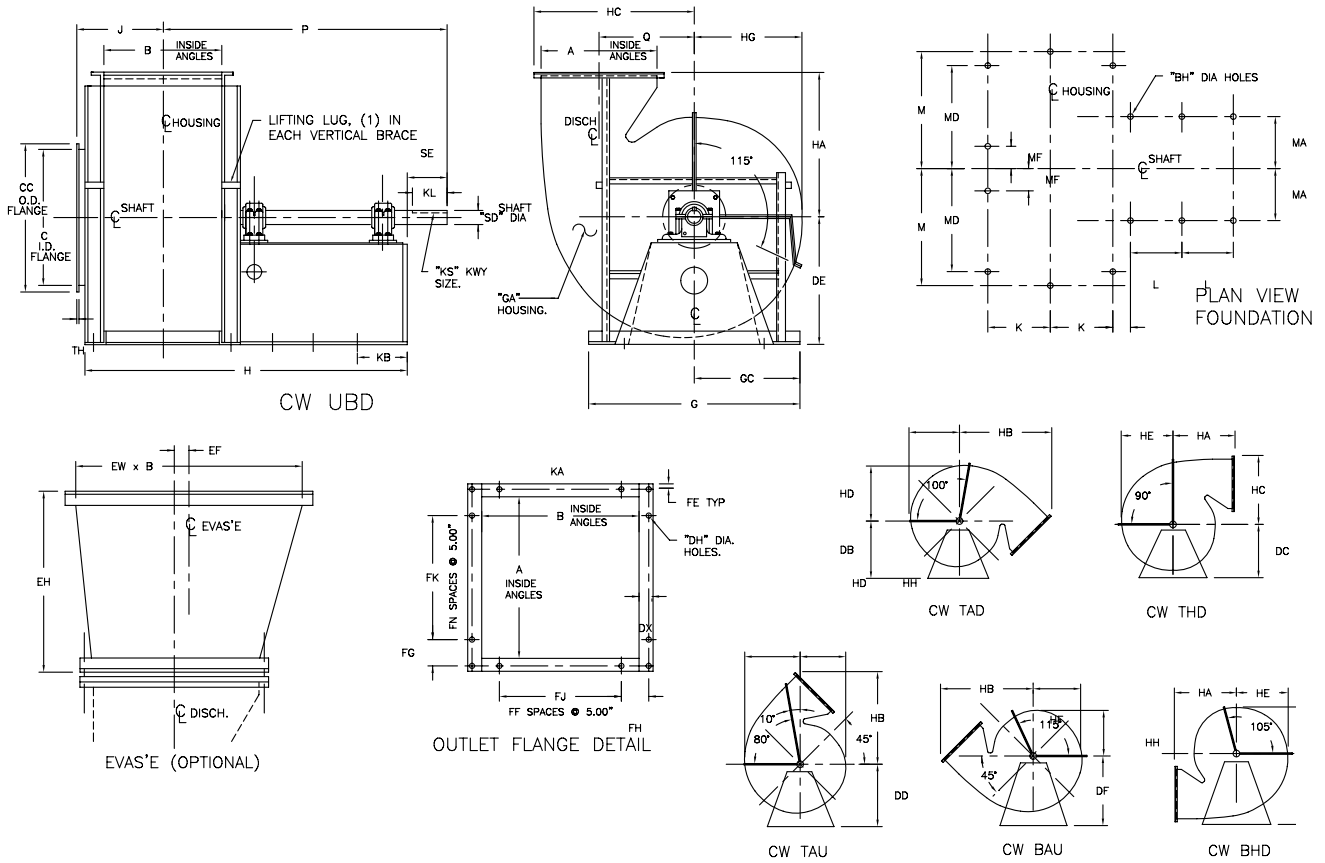

FAN SIZE	A	B	BC	BH	C	CC	DB CC	DD DE	DF DG	DH	DX	EF	EH	EW	FE	FF	FG	FH	FJ	FK	FN	G
360	741	600	857	27	803	905	737	838	1054	14	51	177	908	1226	22	4	82	75	508	635	5	1448
400	818	660	940	27	886	987	813	921	1168	14	64	196	1016	1353	29	4	126	111	508	635	5	1549
450	902	730	1032	27	978	1080	889	1016	1283	14	64	217	1111	1495	29	5	105	83	635	762	6	1651
490	994	803	1168	27	1080	1232	991	1118	1397	17	64	240	1213	1645	29	5	87	119	635	889	7	1778
540	1099	892	1283	27	1194	1346	1086	1226	1505	17	64	265	1330	1819	29	6	76	100	762	1016	8	1930
600	1216	984	1410	27	1321	1473	1194	1346	1676	17	76	294	1483	2013	35	7	141	89	889	1016	8	2032
660	1340	1083	1543	27	1454	1607	1308	1448	1829	17	76	324	1616	2216	35	7	140	138	889	1143	9	2159
730	1478	1194	1721	27	1607	1810	1448	1613	2007	17	89	356	1794	2448	41	8	152	137	1016	1270	10	2337
800	1635	1321	1892	27	1778	1981	1600	1778	2210	17	89	397	1969	2708	41	9	167	137	1143	1397	11	2464

FAN SIZE	GA		GC	H	HA	HB	HC	HD	HE	HF	HG	HH	J	K	KA	KB	KL	KS		L	M
	CL 18	CL 24																CL 18	CL 24		
360	5	6	724	1540	892	1327	984	824	781	738	695	652	432	351	178	102	210	19 x 10	22 x 11	254	673
400	5	6	775	1600	984	1468	1092	908	862	814	768	721	462	381	152	76	229	22 x 11	25 x 13	279	724
450	5	6	826	1746	1086	1616	1200	1003	953	900	849	797	497	416	175	98	229	22 x 11	25 x 13	295	775
490	5	6	889	1908	1194	1775	1316	1105	1048	991	933	876	535	452	171	121	254	25 x 13	25 x 13	330	838
540	5	6	965	2022	1321	1959	1449	1224	1160	1097	1033	970	605	497	149	143	254	25 x 13	25 x 13	330	889
600	6	6	1016	2153	1461	2172	1610	1353	1283	1213	1143	1073	651	543	156	137	273	25 x 13	32 x 16	349	940
660	6	6	1080	2276	1607	2383	1764	1489	1413	1335	1259	1181	700	592	175	130	279	25 x 13	32 x 16	356	1003
730	6	6	1168	2464	1772	2634	1953	1635	1559	1475	1389	1305	783	648	165	140	279	25 x 13	32 x 16	381	1067
800	6	6	1232	2692	1959	2907	2151	1818	1724	1630	1537	1443	846	711	203	152	298	32 x 16	32 x 16	406	1130

FAN SIZE	MA	MD	MF	NH	P	Q	SD		SE	TH
							CL 18	CL 24		
360	406	584	165	24	1367	564	75	87	229	5
400	457	635	191	32	1422	621	87	100	254	5
450	508	635	216	32	1534	686	87	100	254	5
490	559	699	241	40	1684	756	100	113	279	6
540	610	749	267	40	1729	837	100	113	279	6
600	660	800	292	40	1832	926	113	125	298	6
660	711	864	318	40	1913	1018	113	125	305	6
730	762	927	343	48	2019	1126	113	125	305	8
800	813	991	368	48	2203	1245	125	138	324	8

NOTES:

1. CW rotation shown, CCW rotation is similar but opposite.
2. Size 800 will be supplied with channel sub-base to be mounted on concrete pedestal in the field.
3. Standard accessories: bolted access door, housing drain, pie split housing, shaft seal, punched inlet & outlet flanges.

BC9986G

DIMENSIONS ARE NOT TO BE USED FOR CONSTRUCTION. CERTIFIED DRAWINGS AVAILABLE UPON REQUEST.



Model RTF

Fans shall be Model RTF Radial Tip Fans as manufactured by Twin City Fan & Blower, Minneapolis, Minnesota.

PERFORMANCE — Performance ratings shall conform to AMCA Standard 205 (fan efficiency grade) and 211 (air performance). Fans shall be tested in accordance with ANSI/AMCA Standard 210 (air performance) and 300 (sound performance) in an AMCA accredited laboratory. Fans shall be licensed to bear the AMCA certified ratings seal for air and fan efficiency grade (FEG).

HOUSING — Housings shall be made of plate steel with continuously welded construction and braced with structural shapes to eliminate any resonant vibration and to provide smooth operation. Size 360 and larger housings shall have a pie-shaped split for easy impeller and shaft removal without disturbing inlet and outlet ductwork. The housing split must be fully gasketed and bolted together to prevent any leaks. Flanged inlet and outlet, inspection door, shaft seal and drain shall be provided as standard equipment. Bearing support members shall be fabricated of heavy steel shapes or made of concrete to insure maximum rigidity.

IMPELLER — Blade design shall be curved forward at the entering edge to meet air at the correct angle of entry for high efficiency and radial at the tip of the leaving edge to provide a self-cleaning characteristic. Blades shall be formed from high strength low alloy material for strength and accuracy of contour and continuously welded to the inlet shroud and backplate. A heavy fabricated steel hub shall be provided. Impellers shall be shrunk fit on the shafts and hubs must include puller holes for use in event of impeller removal. All impellers shall be statically and dynamically balanced on precision electronic machines, as well as trim balanced during the factory test run.

SHAFT — Shafts shall be AISI 1040 or 1045 hot rolled steel, accurately turned, ground, polished, and ring gauged for accuracy. Shafts shall be sized for the first critical speed of at least 1.43 times the maximum speed.

BEARINGS — Fans shall be supplied with heavy duty, self-aligning, grease lubricated, anti-friction, pillow block type bearings selected for a minimum average bearing life (AFBMA L-50) in excess of 200,000 hours at the maximum fan RPM. Bearings may be ball or roller with non-split pillow block or spherical roller bearings with split pillow block housing (bearing races not split). Where required, sleeve bearings may be used with appropriate cooling method for high carrying loads.

DRIVE — Motor sheaves shall be cast iron, variable pitch on applications 15 kW and smaller, and fixed pitch on 18.5 kW and larger. Drives and belts shall be located external to the fan casing and rated for 150% of the required motor kW.

FINISH AND COATING — The entire fan assembly, excluding the shaft, shall be thoroughly degreased and deburred before application of a rust-preventative primer. After the fan is completely assembled, a finish coat of paint shall be applied to the entire assembly. The fan shaft shall be coated with a petroleum-based rust protectant. Aluminium components shall be unpainted.

ACCESSORIES — When specified, accessories shall be provided by Twin City Fan & Blower to maintain one source responsibility.

FACTORY RUN TEST — All fans prior to shipment shall be completely assembled and test run as a unit at the specified operating speed or maximum RPM allowed for the particular construction type. Each impeller shall be statically and dynamically balanced in accordance with ANSI/AMCA 204-96 "Balance Quality and Vibration Levels for Fans" to Fan Application Category BV-3, Balance Quality Grade G6.3. Balance readings shall be taken by electronic type equipment in the axial, vertical, and horizontal directions on each of the bearings. Records shall be maintained and a written copy shall be available upon request.

GUARANTEE — The manufacturer shall guarantee the workmanship and materials for at least one (1) year from start-up or eighteen (18) months from shipment, whichever occurs first.



INDUSTRIAL PROCESS AND COMMERCIAL VENTILATION SYSTEMS

CENTRIFUGAL FANS | UTILITY SETS | PLENUM & PLUG FANS | INLINE CENTRIFUGAL FANS
MIXED FLOW FANS | TUBEAXIAL & VANEAXIAL FANS | PROPELLER WALL FANS | PROPELLER ROOF VENTILATORS
CENTRIFUGAL ROOF & WALL EXHAUSTERS | CEILING VENTILATORS | GRAVITY VENTILATORS | DUCT BLOWERS
RADIAL BLADED FANS | RADIAL TIP FANS | HIGH EFFICIENCY INDUSTRIAL FANS | PRESSURE BLOWERS
LABORATORY EXHAUST FANS | FILTERED SUPPLY FANS | MANCOOLERS | FIBERGLASS FANS | CUSTOM FANS



TWIN CITY FAN & BLOWER
WWW.TCF.COM

5959 TRENTON LANE N | MINNEAPOLIS, MN 55442 | PHONE: 763-551-7600 | FAX: 763-551-7601

©2018 Twin City Fan Companies, Ltd., Minneapolis, MN. All rights reserved. Catalog illustrations cover the general appearance of Twin City Fan & Blower products at the time of publication and we reserve the right to make changes in design and construction at any time without notice.